

Build Better.

**BENEX**

# **Benex Masonry**

# **Technical Manual**

# Contents

## Preface

**1. Benex Masonry Applications**

**2. Building Code of Australia Compliance**

**3. Structural Design**

**4. Fire Performance**

**5. Acoustic Performance**

**6. Thermal Performance**

**7. Detailing**

**8. Specifications**

**9. Sustainability**

**Appendix A - Benex Masonry Applications**

**Appendix B - Building Code of Australia Compliance**

**Appendix C - Structural Design**

**Appendix D - Fire Performance**

**Appendix E - Acoustic Performance**

**Appendix F - Thermal Performance**

**Appendix G - Detailing**

**Appendix H - Specifications**

**Appendix I - Sustainability**

# Preface

## **Benex Masonry**

Benex Masonry is an innovative interlocking light-weight masonry system, constructed using proprietary thin-bed mortar. Due to its high durability and low permeability to rain penetration, Benex Masonry is suitable for both internal and external use. It may be used in unreinforced applications for internal walls, or for well-supported external walls; or in reinforced applications when constructed as large panels subjected to relatively high wind or earthquake loads.

## **Technical Manual to be used by Professional Architects, Engineers and Builders**

This manual is intended for use by qualified and experienced architects, engineers and builders. The authors, publishers and distributors of this manual, sample specification and the associated drawings do not accept any responsibility for incorrect, inappropriate or incomplete use of this information.

## **Using this Manual**

This manual, including the design recommendations, sample specification and the associated drawings, are available in electronic format, with the express intention that designers will edit them to suit the particular requirements of specific construction projects.

## **Basis of the Specification and Drawings**

This manual has been prepared in the context of the Building Code of Australia. Architects, engineers and builders should make themselves aware of any recent changes to these documents, to any Standards referred to therein or to local variations or requirements. The authors, publishers and distributors of this specification and the associated drawings do not accept any responsibility for failure to do so.

In the preparation of this manual, the following convention has been adopted.

- All building design and construction must comply with the Building Code of Australia and any relevant Australian Standards referred to therein.
- If the construction is not covered by either Building Code of Australia or Australian Standards, construction should comply with a balanced combination of current practice, engineering principles and supplier's information.

## **Occupational Health and Safety**

Benex Masonry is lightweight; easy to cut, drill and nail; and fixed with strong adhesive. This results in lower risk of injury to workers, than is associated with conventional masonry. For details of Occupational Health and Safety considerations, see Detailing - Appendix H Specifications.

## **Further Information**

For further information on Benex Masonry and its use, refer to [www.benexblock.com.au](http://www.benexblock.com.au)

## 1. Benex Masonry Applications

Benex Masonry is a unique new masonry system that can deliver a high quality, thermally efficient and cost effective structural wall system. The system is ideally suited for:

- Housing
- Industrial Buildings
- Commercial Buildings.



Benex Masonry's unique interlocking system enables rapid construction with a minimum of laying skill – so easy it's almost child's play.

Benex Masonry is soft enough to cut with a hand saw.

Benex Masonry is soft enough to drive nails by hand-held hammer or nail-gun, but strong enough to resist loosening.

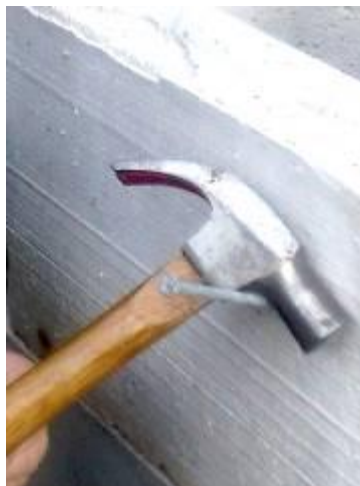

Benex Masonry's close-tolerance and proprietary thin-bed adhesive jointing system provides high bond strength, well in excess of conventional masonry laid in cement mortar.



Benex Masonry's patented lightweight material provides improved thermal and acoustic performance.

Benex Masonry's large "minimum-taper" cores permit the use of steel reinforcement, to resist wind and earthquake loads.



Benex Masonry's enhanced fire performance provides compliance with the Building Code of Australia fire and bushfire requirements.

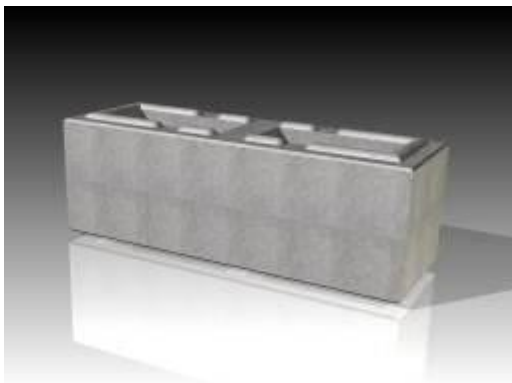

Benex Masonry consists of:

- 600 x 200 x 200 wide mm hollow masonry units, and
- 600 x 200 x 100 wide mm solid masonry units.

Both systems feature formed nibs and matching recesses, for use with thin-bed adhesive, to facilitate rapid and accurate construction. The hollow unit system incorporates large cores for easy reinforcement.

## Design Procedure

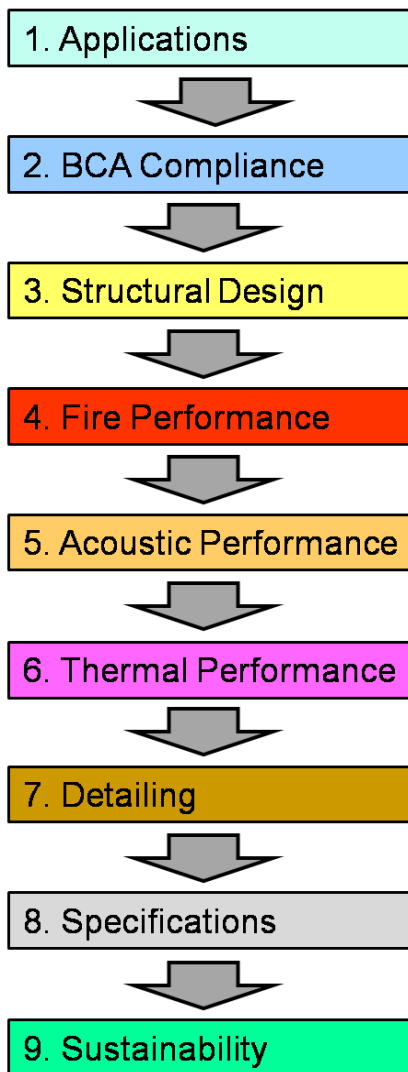

1. Determine the building use and the Building Class, as defined in the Building Code of Australia.
2. Determine the appropriate clauses of the Building Code of Australia, to which the Benex Masonry structure must comply.
3. Carry out structural design of the Benex Masonry system and its supporting structure.
  - Determine the structural support arrangements (concrete slabs, steel or timber frames and the like), together with the spacings and spans. Check the robustness limits of AS 3700.
  - Determine the wind loads, using AS/NZS 1170.2 (or AS 4055 for detached dwellings). Determine the earthquake loads, using AS 1170.4. Determine all other structural loads and loading combinations, using AS/NZS 1170.0, 1 and 3.
  - Check the bending, shear, compression, and connection strength for out-of-plane loads such as wind or earthquake.
  - Check the shear resistance and connection strength for in-of-plane horizontal loads such as wind or earthquake.
  - Check the compressive capacity and resistance to concentrated loads for gravity and other vertical loads. Where appropriate, check connection strength.
4. Determine the fire resistance requirements of structural adequacy, integrity and insulation (if any), using the BCA, and whether the Benex Masonry has sufficient fire resistance. For structural adequacy, the support locations, strength and stiffness must be considered.
5. Determine the acoustic requirements (if any), using the BCA, and whether the Benex Masonry has sufficient sound attenuation. Consider whether this needs to be augmented.
6. Determine the thermal insulation requirements (if any), using the BCA, and whether the Benex Masonry has sufficient thermal resistance. Consider whether this needs to be augmented.
7. Design and detail associated items, such as lintels, roof anchorages, flashings and the like.
8. Prepare a comprehensive materials and construction specification.
9. Check any appropriate sustainability criteria and confirm compliance.

## 2. Building Code of Australia Compliance

### Scope

This section describes the means whereby Benex Masonry satisfies the performance requirements of the Building Code of Australia.

### Performance Requirements, Deemed-to-Satisfy & Alternative Solutions

All building design must comply with the relevant state regulations, which are incorporated into the Building Code of Australia Volume 1 and Volume 2. These define the performance requirements, generally in very broad terms, and the means of compliance through the following paths, each of which has equal status under the Building Code of Australia.

- Deemed-to-Satisfy Provisions, which may include:
  - Acceptable Construction Manuals (e.g. nominated Standards)
  - Acceptable Construction Practice (e.g. forms of construction reproduced in the Building Code of Australia itself)
- Alternative Solutions (e.g. Designs based on test results and engineering principles).

### Definitions

These definitions are taken from the Building Code of Australia Volume 2. Some of the definitions of in Volume 1 have slightly different wording, but essentially mean the same.

**Objective** ... means a statement contained in the Building Code of Australia which is considered to reflect community expectations.

**Functional Statement** ... means a statement which describes how buildings and building elements achieve the Objectives.

**Performance Requirement** ... means a requirement which states a level of performance which a Building Solution must meet.

**Deemed-to-Satisfy Provisions** ...means the provisions contained in Section 3 which are deemed to comply with the Performance Requirements.

**Alternative Solution** ... means a Building Solution which complies with the Performance Requirements other than by reason of complying with the Deemed-to-Satisfy Provisions.

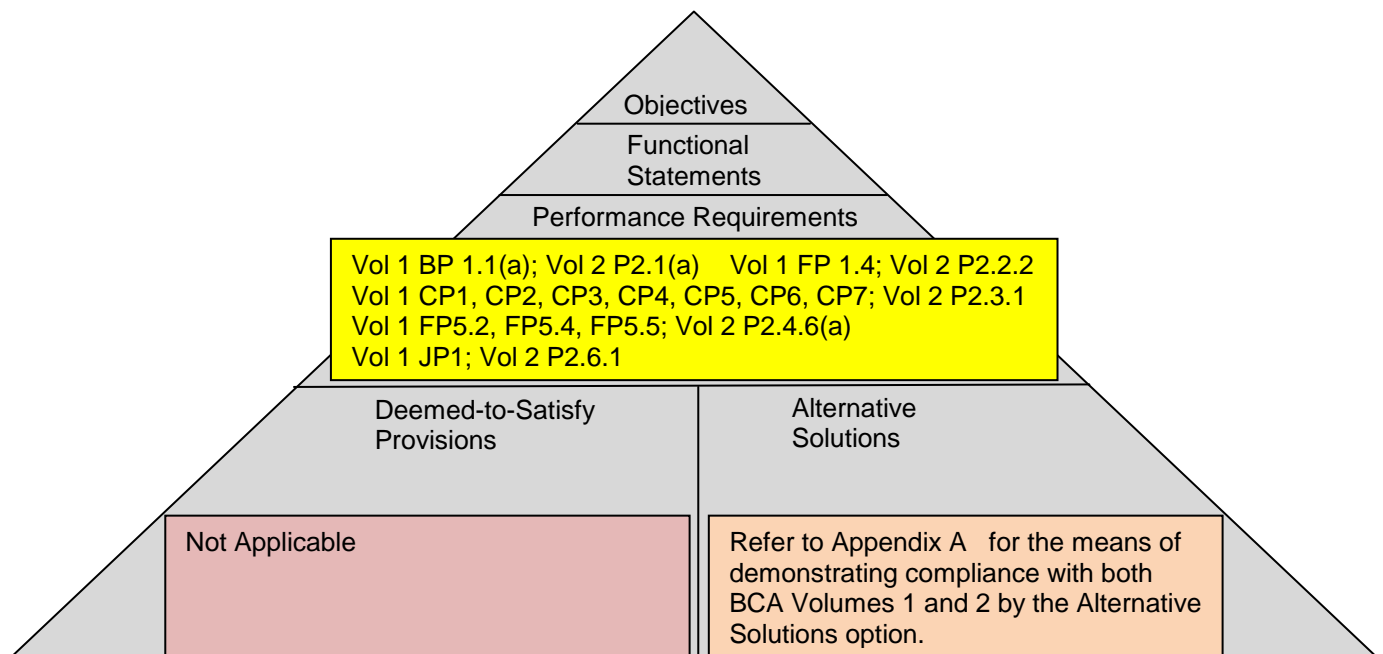

### Benex Masonry in the Context of the Building Code of Australia

The use of Benex Masonry in buildings must comply with the Building Code of Australia. Because Benex Masonry is outside the scope of the most relevant referenced document, AS 3700, its use must be treated as an Alternative Solution.

### Building Regulation Clauses Establishing the Basis of an Alternative Solution

Appendix B sets out the relevant clauses of the Building Code of Australia that provide the basis of establishing an Alternative Solution for the use of Benex Masonry in buildings.

### Compliance Statement

Benex Masonry complies with Building Code of Australia (BCA) as follows:

1. Volume 1 BP1.1(a), Volume 1 BP1.2, and BCA Volume 2 P2.1(a) –  
 200 mm hollow Benex Masonry designed and constructed in accordance with Benex Technologies “Benex Masonry Technical Manual” (D08020701-1), Section 4 and Appendix C.
2. Volume 1 CP1, CP2, CP3, CP4, CP5, CP6, CP7, and BCA Volume 2 P2.3.1 –  
 200 mm hollow Benex Masonry for Fire Resistance Levels of 240/240/180, with a slenderness (as defined in AS 3700) up to 11.25, and up to 75 kN/m working load; and  
 Reinforced 200 mm hollow Benex Masonry, complying with AS 3700 Sections 6 and 8, for Fire Resistance Levels of 240/240/180, with a slenderness (as defined in AS 3700) up to 36.
3. Volume 1 FP5.2, FP5.4, FP5.5 and BCA Volume 2 P2.4.6(a) -  
 200 mm hollow Benex Masonry, with a cavity, resilient clips and 10 mm plasterboard on one side; and a 50 mm cavity and 100 mm solid Benex Masonry on the other, for applications requiring  $R_w$  of 50.
4. Volume 1 Part J and Volume 2 Part 3.12.  
 The thermal resistance of 200 mm hollow Benex Masonry, which may contribute to the total thermal resistance of a wall system, has a value of  $R 0.52 \text{ m}^2.K/W$

Subject to the following conditions and limitations:

1. Product selection, and incorporation into the building design, shall be made by a Professional Engineer who:
  - Has qualifications and experience acceptable to the relevant approval authorities;
  - Has received training in the use, application and technical aspects of the product; and
  - Has ready access to all to the relevant technical information and test reports related to the product use, including Benex Technologies “Benex Masonry Technical Manual”.
2. Product installation, shall be carried out by authorised Benex installers, under the direction of a Builder, both of whom:
  - Have qualifications and experience acceptable to the relevant approval authorities;
  - Have received training in the use, application and technical aspects of the product; and
  - Have ready access to all to the relevant technical information and test reports related to the product use, including Benex Technologies “Benex Masonry Technical Manual”.

Notes: The state administrations have differing requirements in respect of qualifications of structural engineers, including registration on the National Professional Engineers Register, and Registered Professional Engineer Queensland.

### 3. Structural Design

#### Scope

This section covers the structural design of Benex Masonry for compliance with the structural requirements of the Building Code of Australia.

#### Forms of Construction

Benex Masonry is an innovative interlocking light-weight masonry system, constructed using proprietary thin-bed mortar. It may be used in unreinforced applications for internal walls, or for well-supported external walls; or in reinforced applications when constructed as large panels subjected to relatively high wind or earthquake loads.

#### Option 1 – 200 mm Unreinforced Benex Internal or External Walls

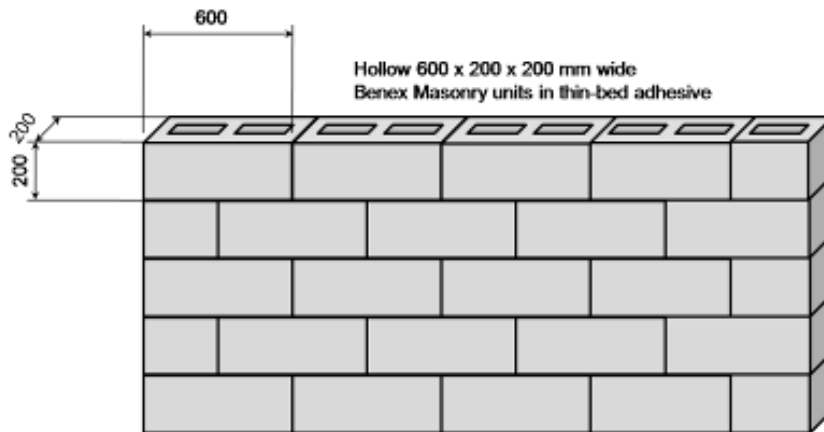

#### Option 2 – 200 mm Reinforced Benex Internal or External walls

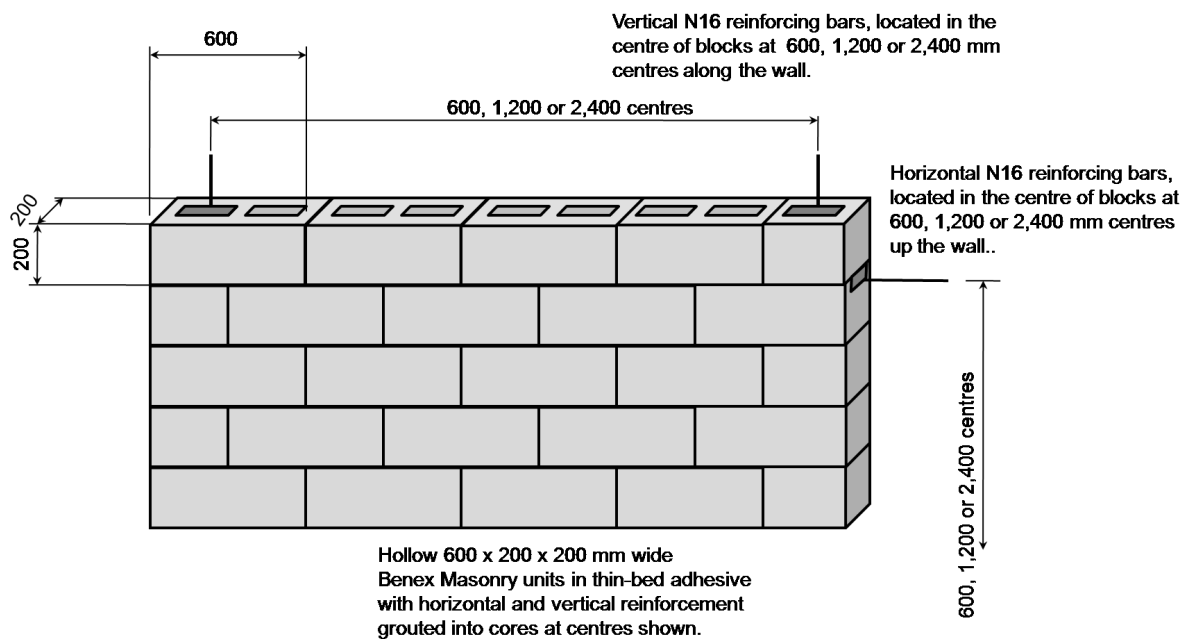

## **Building Code of Australia**

The structural design of Benex Masonry within buildings is regulated by the Building Code of Australia. Refer to the section “Compliance with the Building Code of Australia”.

## **Relevant Standard**

Benex Masonry is outside the scope of the most relevant Building Code of Australia referenced document, AS 3700, and its use must be treated, under the Building Code of Australia, as an Alternative Solution.

AS 3700 covers the design and construction of masonry, including unreinforced, reinforced and prestressed, using manufactured units of clay, calcium silicate and concrete laid in mortar, autoclaved aerated concrete laid in thin-bed mortar, and square-dressed natural stone laid in mortar. Because the behaviour and properties of Benex Masonry are similar to masonry, comparison is made to AS 3700 for purposes of justifying the Alternative Solution.

## **CSIRO Report**

The above-mentioned approach is reflected in CSIRO Report No DTS767 (dated 30/10/07), which involved the testing of Benex Masonry, and comparing the results to other masonry covered by AS 3700. The CSIRO report makes a number of recommendations, which have been adopted in this manual, and demonstrated in Appendix C.

## **Performance**

200 mm hollow Benex Masonry designed and constructed in accordance with Benex Technologies “Benex Masonry Technical Manual” (D08020701-1), Section 4 and Appendix C comply with the requirements of Volume 1 BP1.1(a), Volume 1 BP1.2, and BCA Volume 2 P2.1(a). Refer to Appendix C for the details.

## **Loads**

Benex Masonry walls should be designed to withstand the loads set out in the Building Code of Australia and Standards:

AS/NZS 1170.0 Structural design actions Part 0: General principles  
AS/NZS 1170.1 Structural design actions Part 1: Permanent, imposed and other actions  
AS/NZS 1170.2 Structural design actions Part 2: Wind actions  
AS/NZS 1170.3 Structural design actions Part 3: Snow and ice actions  
AS 1170.4 Structural design actions Part 4: Earthquake actions in Australia  
AS 4055 Wind loads for housing

## **Design for Bending – Capacity Tables**

The following pages set out bending capacity tables for unreinforced and reinforced Benex Masonry subject to horizontal pressures as would arise from wind or earthquake loading. The basis of these tables is set out in Appendix C. The fixing of Benex Masonry into the supporting structure should be carried out in accordance with Appendix C.

## **Design for Other Actions**

The design of Benex Masonry for other actions, such as Compression and Shear, should be carried out in accordance with the method set out in Appendix C.

## Wall Panel Support

All Benex Masonry wall panels must be adequately fixed into the structure. Guidance is given in Appendix C.

In particular, the connections of Reinforced Benex Masonry, which is capable of spanning large distances at significant lateral loads, must be designed and constructed for the wind, earthquake, fire and accidental loads that can occur. Reinforced Benex Masonry should be considered similar to “a concrete external wall that could collapse as a complete panel”. The connection such panels must comply with BCA Volume 1 Part CP5, which states:

*A concrete external wall that could collapse as a complete panel (e.g.. tilt-up and pre-cast concrete) must be designed so that in the event of fire within the building the likelihood of outward collapse is avoided. Limitation: CP5 does not apply to a building having more than two storeys above ground level.*

## Option 1 – 200 mm wide Unreinforced Internal or External Walls

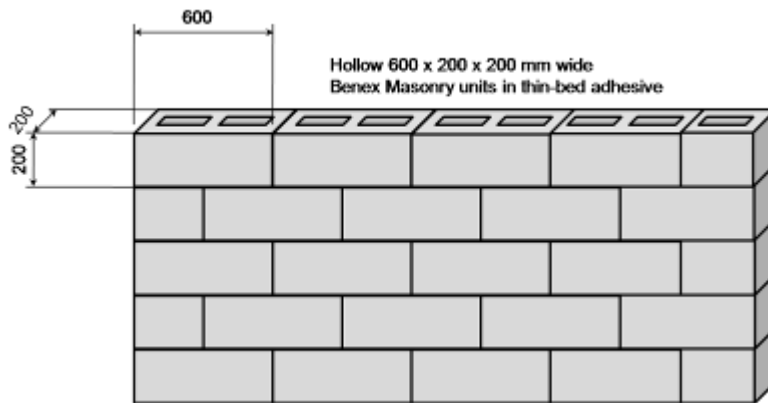

The following tables provide lateral capacities (in kPa) of 200 mm Unreinforced Benex Masonry, supported on all four sides to the structure, i.e. fixed to both columns, a strong/stiff top beam, and at the base. The designer must determine the design load (kPa) and compare this to the tabulated capacity (kPa).

Three options are given, depending on the continuity of the masonry past the columns (vertical supports). The following points affect the assumption of continuity:

- Anchors of sufficient strength must be provided regularly at sides and top supports to ensure that resistance to horizontal loads is adequate.
- The inclusion of a vertical control joint at a support infers that continuity cannot be provided at that support.
- Spacing of supports in adjacent wall panels must be considered when determining whether continuity is provided.

The following tables are based on CSIRO Report No DTS767 (dated 30/10/07), with the following qualifications.

- The capacities shown in pink are derived from the formula in CSIRO Report No DTS767, with an upper limit on H/L of 1.15 and application within the robustness limitations of AS 3700 for two-way action. The formula in the report is based on tests of walls with the following dimensions. Height (m) x Length (m) of 3.0 x 6.0, 3.0 x 3.8 and 3.0 x 2.6. This corresponds to H/L aspect ratios in the range 0.5 to 1.15. An upper limit on H/L of 1.15 has been adopted. If this limit were not applied, the capacity would increase beyond values that could be reasonably expected based on the tests.
- The capacities shown in yellow are derived for one-way horizontal bending between vertical supports at each end.
- The capacities shown in purple are derived for one-way vertical bending between horizontal supports top and bottom.
- The capacities shown in green are derived by averaging the values immediately below and values immediately to the right. This provides a smooth transition between two-way bending and one-way horizontal bending.
- Walls must be designed to resist the horizontal wind, earthquake, fire and accidental loading determined in accordance with AS 1170, which may be in the range of 0.8 to 3.5 kPa, depending on location, topography exposure and the like. In no case should walls have a capacity of less than 0.5 kPa, even in internal applications. Therefore the tables do not provide capacities less than 0.5 kPa.

## 200 mm Unreinforced Benex Masonry - Lateral Load Capacity (kPa)

Vertical robustness coefficient	$C_v$	27.00
Horizontal robustness coefficient	$C_h$	36.00
Vertical bending coefficient	$b_v$	1.00
Horizontal bending coefficient	$b_h$	1.00
Vertical bending moment capacity	$M_{cv}$	0.580 kN.m/m
Horizontal bending moment capacity	$M_{ch}$	0.815 kN.m/m
Robustness thickness	$t_r$	200 mm

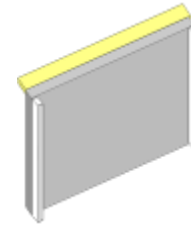

### Length between vertical supports, L (m)

Height H (m)	Length between vertical supports, L (m)											
	2.4	3.0	3.6	4.2	4.8	5.4	6.0	6.6	7.2	7.8	8.4	9.0
10.0	0.81	0.52										
9.8	0.81	0.52										
9.6	0.81	0.52										
9.4	0.81	0.52										
9.2	0.81	0.52										
9.0	0.81	0.52										
8.8	0.81	0.52										
8.6	0.81	0.52										
8.4	0.81	0.52										
8.2	0.81	0.52										
8.0	0.81	0.52										
7.8	0.81	0.52										
7.6	0.81	0.52										
7.4	0.81	0.52										
7.2	0.81	0.52										
7.0	0.81	0.52										
6.8	0.81	0.52										
6.6	0.81	0.52										
6.4	0.81	0.52										
6.2	0.81	0.52										
6.0	0.96	0.90	0.85	0.80	0.76	0.73	0.58					
5.8	1.02	0.96	0.90	0.84	0.78	0.73	0.58					
5.6	1.08	1.02	0.96	0.90	0.83	0.72	0.58					
5.4	1.14	1.08	1.02	0.96	0.93	0.72	0.57					
5.2	1.20	1.14	1.08	1.00	0.92	0.71	0.57					
5.0	1.26	1.21	1.16	1.07	0.92	0.71	0.57					
4.8	1.30	1.27	1.24	1.22	0.91	0.71	0.57					
4.6	1.33	1.30	1.26	1.21	0.90	0.71	0.58					
4.4	1.35	1.35	1.31	1.20	0.90	0.71	0.58					
4.2	1.36	1.39	1.42	1.19	0.90	0.71	0.58					
4.0	1.32	1.36	1.65	1.18	0.90	0.71	0.59					
3.8	1.28	1.07	1.63	1.17	0.90	0.72	0.60	0.51				
3.6	1.48	0.52	1.61	1.17	0.90	0.73	0.61	0.52				
3.4	2.45	2.39	1.60	1.17	0.91	0.74	0.62	0.53				
3.2	2.51	2.36	1.59	1.18	0.92	0.75	0.63	0.55				
3.0	2.66	2.33	1.59	1.19	0.94	0.77	0.65	0.57	0.52	0.52	0.52	0.52
2.8	3.00	2.30	1.60	1.20	0.96	0.79	0.68	0.59	0.59	0.59	0.59	0.59
2.6	3.69	2.29	1.61	1.23	0.98	0.82	0.70	0.69	0.69	0.69	0.69	0.69
2.4	3.63	2.30	1.64	1.26	1.02	0.86	0.81	0.81	0.81	0.81	0.81	0.81

## 200 mm Unreinforced Benex Masonry - Lateral Load Capacity (kPa)

Vertical robustness coefficient	$C_v$	27.00
Horizontal robustness coefficient	$C_h$	36.00
Vertical bending coefficient	$b_v$	1.00
Horizontal bending coefficient	$b_h$	1.25
Vertical bending moment capacity	$M_{cv}$	0.580 kN.m/m
Horizontal bending moment capacity	$M_{ch}$	0.815 kN.m/m
Robustness thickness	$t_r$	200 mm

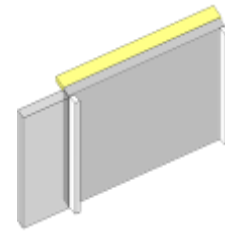

Height H (m)	Length between vertical supports, L (m)											
	2.4	3.0	3.6	4.2	4.8	5.4	6.0	6.6	7.2	7.8	8.4	9.0
10.0	0.81	0.52										
9.8	0.81	0.52										
9.6	0.81	0.52										
9.4	0.81	0.52										
9.2	0.81	0.52										
9.0	0.81	0.52										
8.8	0.81	0.52										
8.6	0.81	0.52										
8.4	0.81	0.52										
8.2	0.81	0.52										
8.0	0.81	0.52										
7.8	0.81	0.52										
7.6	0.81	0.52										
7.4	0.81	0.52										
7.2	0.81	0.52										
7.0	0.81	0.52										
6.8	0.81	0.52										
6.6	0.81	0.52										
6.4	0.81	0.52										
6.2	0.81	0.52										
6.0	1.11	1.04	0.98	0.92	0.87	0.85	0.67	0.54				
5.8	1.18	1.11	1.04	0.97	0.90	0.84	0.66	0.54				
5.6	1.25	1.18	1.11	1.04	0.96	0.83	0.66	0.53				
5.4	1.32	1.25	1.18	1.12	1.08	0.82	0.65	0.53				
5.2	1.39	1.32	1.24	1.15	1.07	0.81	0.65	0.53				
5.0	1.45	1.40	1.34	1.24	1.05	0.81	0.64	0.53				
4.8	1.50	1.47	1.44	1.42	1.04	0.80	0.64	0.53				
4.6	1.53	1.50	1.45	1.40	1.03	0.80	0.64	0.53				
4.4	1.55	1.55	1.51	1.38	1.02	0.79	0.64	0.53				
4.2	1.55	1.60	1.64	1.36	1.01	0.79	0.64	0.54				
4.0	1.50	1.56	1.91	1.34	1.01	0.79	0.65	0.54				
3.8	1.44	1.20	1.88	1.33	1.00	0.79	0.65	0.55				
3.6	1.67	0.52	1.85	1.32	1.00	0.80	0.66	0.56				
3.4	2.83	2.78	1.82	1.31	1.00	0.80	0.67	0.57				
3.2	2.89	2.72	1.80	1.31	1.01	0.81	0.68	0.58	0.51			
3.0	3.05	2.66	1.79	1.31	1.02	0.83	0.70	0.60	0.53	0.52	0.52	0.52
2.8	3.44	2.62	1.78	1.32	1.03	0.85	0.72	0.62	0.59	0.59	0.59	0.59
2.6	4.27	2.59	1.78	1.33	1.06	0.87	0.74	0.69	0.69	0.69	0.69	0.69
2.4	4.16	2.57	1.79	1.36	1.09	0.90	0.81	0.81	0.81	0.81	0.81	0.81

## 200 mm Unreinforced Benex Masonry - Lateral Load Capacity (kPa)

Vertical robustness coefficient	$C_v$	27.00
Horizontal robustness coefficient	$C_h$	36.00
Vertical bending coefficient	$b_v$	1.00
Horizontal bending coefficient	$b_h$	1.50
Vertical bending moment capacity	$M_{cv}$	0.580 kN.m/m
Horizontal bending moment capacity	$M_{ch}$	0.815 kN.m/m
Robustness thickness	$t_r$	200 Mm

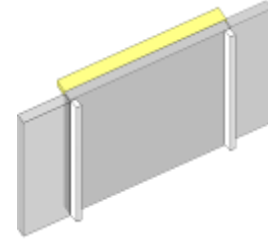

Height H (m)	Length between vertical supports, L (m)												
	2.4	3.0	3.6	4.2	4.8	5.4	6.0	6.6	7.2	7.8	8.4	9.0	
10.0	0.81	0.52											
9.8	0.81	0.52											
9.6	0.81	0.52											
9.4	0.81	0.52											
9.2	0.81	0.52											
9.0	0.81	0.52											
8.8	0.81	0.52											
8.6	0.81	0.52											
8.4	0.81	0.52											
8.2	0.81	0.52											
8.0	0.81	0.52											
7.8	0.81	0.52											
7.6	0.81	0.52											
7.4	0.81	0.52											
7.2	0.81	0.52											
7.0	0.81	0.52											
6.8	0.81	0.52											
6.6	0.81	0.52											
6.4	0.81	0.52											
6.2	0.81	0.52											
6.0	1.26	1.19	1.11	1.05	0.99	0.97	0.75	0.60					
5.8	1.34	1.26	1.18	1.10	1.02	0.95	0.74	0.60					
5.6	1.42	1.34	1.26	1.18	1.09	0.94	0.73	0.59					
5.4	1.50	1.42	1.34	1.27	1.23	0.93	0.73	0.59					
5.2	1.57	1.50	1.41	1.31	1.21	0.92	0.72	0.59					
5.0	1.64	1.59	1.52	1.41	1.19	0.90	0.71	0.58					
4.8	1.70	1.67	1.63	1.62	1.17	0.89	0.71	0.58					
4.6	1.72	1.70	1.65	1.59	1.16	0.89	0.71	0.58					
4.4	1.75	1.75	1.71	1.56	1.14	0.88	0.70	0.58					
4.2	1.74	1.80	1.85	1.53	1.13	0.87	0.70	0.58					
4.0	1.67	1.75	2.18	1.51	1.12	0.87	0.70	0.58					
3.8	1.59	1.32	2.13	1.49	1.11	0.87	0.70	0.59	0.50				
3.6	1.86	0.52	2.09	1.47	1.10	0.87	0.71	0.60	0.51				
3.4	3.21	3.16	2.05	1.45	1.10	0.87	0.72	0.60	0.52				
3.2	3.26	3.08	2.01	1.44	1.10	0.88	0.72	0.62	0.53				
3.0	3.45	3.00	1.98	1.43	1.10	0.89	0.74	0.63	0.55	0.52	0.52	0.52	
2.8	3.89	2.94	1.96	1.43	1.11	0.90	0.76	0.65	0.59	0.59	0.59	0.59	
2.6	4.84	2.88	1.95	1.44	1.13	0.92	0.78	0.69	0.69	0.69	0.69	0.69	
2.4	4.69	2.84	1.95	1.46	1.15	0.95	0.81	0.81	0.81	0.81	0.81	0.81	0.81

## Option 2 – 200 mm wide Reinforced Internal or External Walls

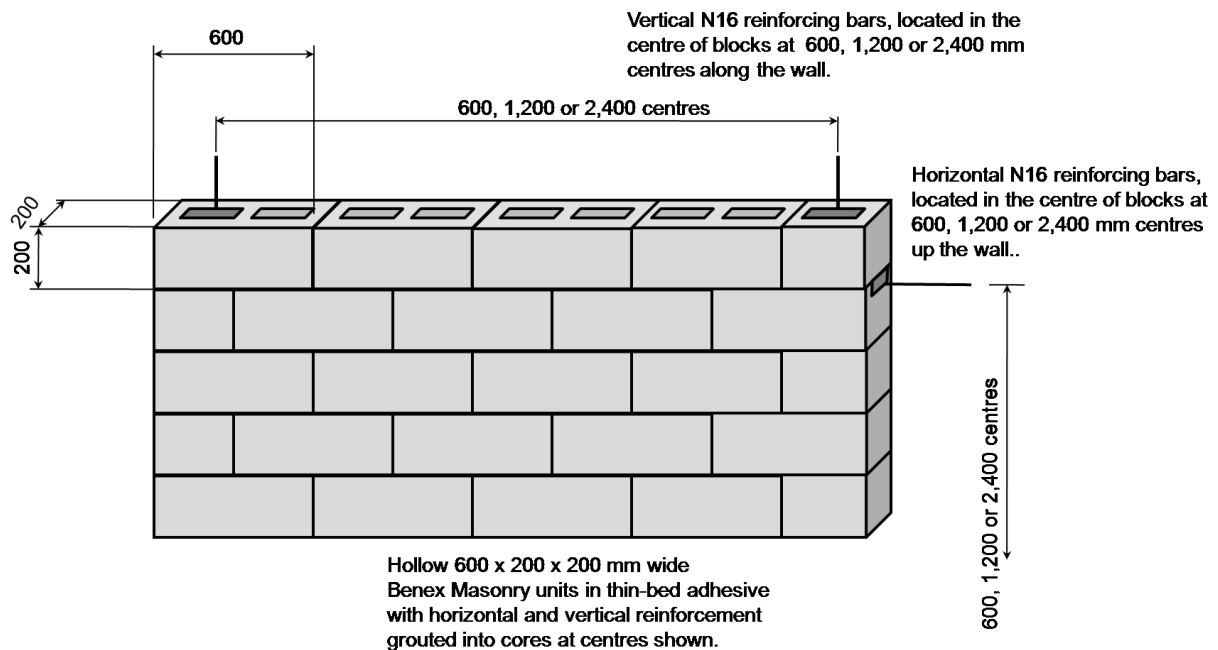

The following table is for 200 mm Reinforced Benex Masonry, supported on all four sides to the structure, i.e. fixed to both columns, a braced strong/stiff top beam, and at the base with connectors designed to transmit the loads to the supports. The designer must determine the design load (kPa) and compare this to the tabulated capacity (kPa).

The masonry must be reinforced in accordance with one of the three options, as follows:

1. N16 horizontal and vertical reinforcement at 2,400 mm centres
2. N16 horizontal and vertical reinforcement at 1,200 mm centres
3. N16 horizontal and vertical reinforcement at 600 mm centres

The following tables are based Benex properties reported in CSIRO Report No DTS767 (dated 30/10/07), and the method used in AS 3700 Section 8, with the following qualifications.

- The capacities shown in pink are derived from two way action, by summing the vertical and horizontal capacities, between the limits for H/L of 0.5 to 2.0. Note: This assumption is only valid for approximately equal moment capacities in both directions, i.e. the horizontal and vertical spacing of the reinforcement must be equal.
- The capacities shown in yellow are derived for one-way horizontal bending between vertical supports at each end.
- The capacities shown in purple are derived for one-way vertical bending between horizontal supports top and bottom.
- Walls must be designed to resist the horizontal wind, earthquake, fire and accidental loading determined in accordance with AS 1170, which may be in the range of 0.8 to 3.5 kPa, depending on location, topography exposure and the like. In no case should walls have a capacity of less than 0.5 kPa, even in internal applications. Therefore the tables do not provide capacities less than 0.5 kPa.

## 200 mm Benex Masonry, Reinforced Horizontally and Vertically with 1 N16 @ 2,400 mm Lateral Load Capacity (kPa)

Vertical robustness coefficient	$C_v$	36.00
Horizontal robustness coefficient	$C_h$	48.00
Vertical bending moment capacity	$M_{cv}$	1.63 kN.m/m
Horizontal bending moment capacity	$M_{ch}$	1.22 kN.m/m

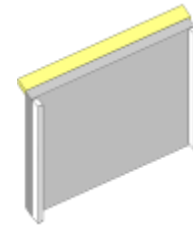

Robustness thickness	$t_r$	200 Mm
----------------------	-------	--------

### Length between vertical supports, L (m)

Height H (m)	2.4	3.0	3.6	4.2	4.8	5.4	6.0	6.6	7.2	7.8	8.4	9.0
10.0	2.26	1.45	1.00	0.74	0.56							
9.8	2.26	1.45	1.00	0.74	0.56							
9.6	2.26	1.45	1.00	0.74	0.56							
9.4	2.26	1.45	1.00	0.74	0.56							
9.2	2.26	1.45	1.00	0.74	0.56							
9.0	2.26	1.45	1.00	0.74	0.56							
8.8	2.26	1.45	1.00	0.74	0.56							
8.6	2.26	1.45	1.00	0.74	0.56							
8.4	2.26	1.45	1.00	0.74	0.56							
8.2	2.26	1.45	1.00	0.74	0.56							
8.0	2.26	1.45	1.00	0.74	0.56							
7.8	2.26	1.45	1.00	0.74	0.56							
7.6	2.26	1.45	1.00	0.74	0.56							
7.4	2.26	1.45	1.00	0.74	0.56							
7.2	2.26	1.45	1.00	0.74	0.56							
7.0	2.26	1.45	1.02	0.80	0.66	0.57	0.50					
6.8	2.26	1.45	1.03	0.81	0.68	0.58	0.51					
6.6	2.26	1.45	1.04	0.83	0.69	0.60	0.53					
6.4	2.26	1.45	1.06	0.84	0.71	0.61	0.54					
6.2	2.26	1.45	1.07	0.86	0.72	0.63	0.56	0.51				
6.0	2.26	1.45	1.09	0.88	0.74	0.65	0.58	0.53				
5.8	2.26	1.47	1.11	0.90	0.76	0.67	0.60	0.55	0.51			
5.6	2.26	1.49	1.13	0.92	0.78	0.69	0.62	0.57	0.53	0.50		
5.4	2.26	1.51	1.16	0.95	0.81	0.71	0.65	0.60	0.56	0.53	0.50	
5.2	2.26	1.54	1.19	0.97	0.84	0.74	0.67	0.62	0.59	0.56	0.53	0.51
5.0	2.26	1.57	1.22	1.01	0.87	0.77	0.71	0.66	0.62	0.59	0.56	0.54
4.8	2.26	1.61	1.25	1.04	0.90	0.81	0.74	0.69	0.65	0.62	0.60	0.58
4.6	2.30	1.65	1.29	1.08	0.94	0.85	0.78	0.73	0.69	0.66	0.64	0.62
4.4	2.34	1.69	1.34	1.13	0.99	0.89	0.83	0.78	0.74	0.71	0.68	0.67
4.2	2.40	1.75	1.39	1.18	1.04	0.95	0.88	0.83	0.79	0.76	0.74	0.74
4.0	2.46	1.81	1.45	1.24	1.10	1.01	0.94	0.89	0.85	0.82	0.81	0.81
3.8	2.53	1.88	1.52	1.31	1.17	1.08	1.01	0.96	0.92	0.90	0.90	0.90
3.6	2.61	1.96	1.61	1.39	1.25	1.16	1.09	1.04	1.00	1.00	1.00	1.00
3.4	2.71	2.06	1.70	1.49	1.35	1.26	1.19	1.14	1.13	1.13	1.13	1.13
3.2	2.82	2.17	1.82	1.61	1.47	1.37	1.31	1.27	1.27	1.27	1.27	1.27
3.0	2.96	2.31	1.96	1.75	1.61	1.51	1.45	1.45	1.45	1.45	1.45	1.45
2.8	3.13	2.48	2.13	1.92	1.78	1.68	1.66	1.66	1.66	1.66	1.66	1.66
2.6	3.35	2.70	2.34	2.13	1.99	1.92	1.92	1.92	1.92	1.92	1.92	1.92
2.4	3.61	2.96	2.61	2.40	2.26	2.26	2.26	2.26	2.26	2.26	2.26	2.26

## 200 mm Benex Masonry, Reinforced Horizontally and Vertically with 1 N16 @ 1,200 mm Lateral Load Capacity (kPa)

Vertical robustness coefficient	$C_v$	36.00	
Horizontal robustness coefficient	$C_h$	48.00	
Vertical bending moment capacity	$M_{cv}$	3.25	kN.m/m
Horizontal bending moment capacity	$M_{ch}$	2.44	kN.m/m

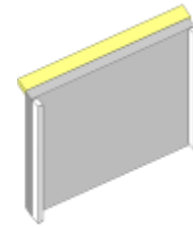

Robustness thickness  $t_r$  200 Mm

### Length between vertical supports, L (m)

Height H (m)	2.4	3.0	3.6	4.2	4.8	5.4	6.0	6.6	7.2	7.8	8.4	9.0
10.0	4.52	2.89	2.01	1.47	1.13	0.89	0.72	0.60	0.50			
9.8	4.52	2.89	2.01	1.47	1.13	0.89	0.72	0.60	0.50			
9.6	4.52	2.89	2.01	1.47	1.13	0.89	0.72	0.60	0.50			
9.4	4.52	2.89	2.01	1.47	1.13	0.89	0.72	0.60	0.50			
9.2	4.52	2.89	2.01	1.47	1.13	0.89	0.72	0.60	0.50			
9.0	4.52	2.89	2.01	1.47	1.13	0.89	0.72	0.60	0.50			
8.8	4.52	2.89	2.01	1.47	1.13	0.89	0.72	0.60	0.50			
8.6	4.52	2.89	2.01	1.47	1.13	0.89	0.72	0.60	0.50			
8.4	4.52	2.89	2.01	1.47	1.13	0.89	0.72	0.60	0.50			
8.2	4.52	2.89	2.01	1.47	1.13	0.89	0.72	0.60	0.50			
8.0	4.52	2.89	2.01	1.47	1.13	0.89	0.72	0.60	0.50			
7.8	4.52	2.89	2.01	1.47	1.13	0.89	0.72	0.60	0.50			
7.6	4.52	2.89	2.01	1.47	1.13	0.89	0.72	0.60	0.50			
7.4	4.52	2.89	2.01	1.47	1.13	0.89	0.72	0.60	0.50			
7.2	4.52	2.89	2.01	1.47	1.13	0.89	0.72	0.60	0.50			
7.0	4.52	2.89	2.03	1.60	1.33	1.14	1.00	0.90	0.83	0.77	0.72	0.68
6.8	4.52	2.89	2.06	1.63	1.35	1.16	1.03	0.93	0.85	0.79	0.75	0.71
6.6	4.52	2.89	2.08	1.66	1.38	1.19	1.06	0.96	0.88	0.82	0.77	0.73
6.4	4.52	2.89	2.11	1.69	1.41	1.22	1.09	0.99	0.91	0.85	0.80	0.77
6.2	4.52	2.89	2.15	1.72	1.44	1.26	1.12	1.02	0.94	0.88	0.84	0.80
6.0	4.52	2.89	2.18	1.76	1.48	1.29	1.16	1.06	0.98	0.92	0.87	0.84
5.8	4.52	2.93	2.22	1.80	1.52	1.33	1.20	1.10	1.02	0.96	0.91	0.88
5.6	4.52	2.98	2.27	1.84	1.57	1.38	1.24	1.14	1.07	1.01	0.96	0.92
5.4	4.52	3.03	2.32	1.89	1.62	1.43	1.29	1.19	1.12	1.06	1.01	0.97
5.2	4.52	3.08	2.38	1.95	1.67	1.48	1.35	1.25	1.17	1.11	1.06	1.03
5.0	4.52	3.14	2.44	2.01	1.74	1.55	1.41	1.31	1.23	1.17	1.13	1.09
4.8	4.52	3.22	2.51	2.08	1.81	1.62	1.48	1.38	1.30	1.25	1.20	1.16
4.6	4.60	3.30	2.59	2.16	1.89	1.70	1.56	1.46	1.39	1.33	1.28	1.24
4.4	4.69	3.39	2.68	2.25	1.98	1.79	1.65	1.55	1.48	1.42	1.37	1.34
4.2	4.79	3.49	2.79	2.36	2.08	1.89	1.76	1.66	1.58	1.52	1.47	1.47
4.0	4.91	3.61	2.91	2.48	2.20	2.01	1.88	1.78	1.70	1.64	1.63	1.63
3.8	5.05	3.75	3.05	2.62	2.34	2.16	2.02	1.92	1.84	1.80	1.80	1.80
3.6	5.22	3.92	3.21	2.79	2.51	2.32	2.18	2.08	2.01	2.01	2.01	2.01
3.4	5.41	4.11	3.41	2.98	2.70	2.51	2.38	2.28	2.25	2.25	2.25	2.25
3.2	5.65	4.34	3.64	3.21	2.94	2.75	2.61	2.54	2.54	2.54	2.54	2.54
3.0	5.93	4.62	3.92	3.49	3.22	3.03	2.89	2.89	2.89	2.89	2.89	2.89
2.8	6.27	4.97	4.26	3.83	3.56	3.37	3.32	3.32	3.32	3.32	3.32	3.32
2.6	6.69	5.39	4.68	4.26	3.98	3.85	3.85	3.85	3.85	3.85	3.85	3.85
2.4	7.23	5.93	5.22	4.79	4.52	4.52	4.52	4.52	4.52	4.52	4.52	4.52

## 200 mm Benex Masonry, Reinforced Horizontally and Vertically with 1 N16 @ 600 Lateral Load Capacity (kPa)

Vertical robustness coefficient	$C_v$	36.00	
Horizontal robustness coefficient	$C_h$	48.00	
Vertical bending moment capacity	$M_{cv}$	4.88	kN.m/m
Horizontal bending moment capacity	$M_{ch}$	4.88	kN.m/m
Robustness thickness	$t_r$	200	Mm

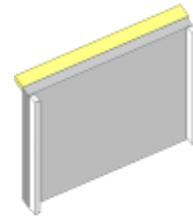

Height H (m)	Length between vertical supports, L (m)											
	2.4	3.0	3.6	4.2	4.8	5.4	6.0	6.6	7.2	7.8	8.4	9.0
10.0	6.77	4.34	3.01	2.21	1.69	1.34	1.08	0.90	0.75	0.64	0.55	
9.8	6.77	4.34	3.01	2.21	1.69	1.34	1.08	0.90	0.75	0.64	0.55	
9.6	6.77	4.34	3.01	2.21	1.69	1.34	1.08	0.90	0.75	0.64	0.55	
9.4	6.77	4.34	3.01	2.21	1.69	1.34	1.08	0.90	0.75	0.64	0.55	
9.2	6.77	4.34	3.01	2.21	1.69	1.34	1.08	0.90	0.75	0.64	0.55	
9.0	6.77	4.34	3.01	2.21	1.69	1.34	1.08	0.90	0.75	0.64	0.55	
8.8	6.77	4.34	3.01	2.21	1.69	1.34	1.08	0.90	0.75	0.64	0.55	
8.6	6.77	4.34	3.01	2.21	1.69	1.34	1.08	0.90	0.75	0.64	0.55	
8.4	6.77	4.34	3.01	2.21	1.69	1.34	1.08	0.90	0.75	0.64	0.55	
8.2	6.77	4.34	3.01	2.21	1.69	1.34	1.08	0.90	0.75	0.64	0.55	
8.0	6.77	4.34	3.01	2.21	1.69	1.34	1.08	0.90	0.75	0.64	0.55	
7.8	6.77	4.34	3.01	2.21	1.69	1.34	1.08	0.90	0.75	0.64	0.55	
7.6	6.77	4.34	3.01	2.21	1.69	1.34	1.08	0.90	0.75	0.64	0.55	
7.4	6.77	4.34	3.01	2.21	1.69	1.34	1.08	0.90	0.75	0.64	0.55	
7.2	6.77	4.34	3.01	2.21	1.69	1.34	1.08	0.90	0.75	0.64	0.55	
7.0	6.77	4.34	3.05	2.41	1.99	1.71	1.50	1.35	1.24	1.15	1.08	1.02
6.8	6.77	4.34	3.08	2.44	2.03	1.75	1.54	1.39	1.28	1.19	1.12	1.06
6.6	6.77	4.34	3.13	2.49	2.07	1.79	1.58	1.43	1.32	1.23	1.16	1.10
6.4	6.77	4.34	3.17	2.53	2.12	1.83	1.63	1.48	1.36	1.28	1.20	1.15
6.2	6.77	4.34	3.22	2.58	2.17	1.88	1.68	1.53	1.41	1.33	1.25	1.20
6.0	6.77	4.34	3.28	2.64	2.22	1.94	1.73	1.58	1.47	1.38	1.31	1.25
5.8	6.77	4.40	3.34	2.70	2.28	2.00	1.80	1.64	1.53	1.44	1.37	1.31
5.6	6.77	4.46	3.40	2.77	2.35	2.07	1.86	1.71	1.60	1.51	1.44	1.38
5.4	6.77	4.54	3.48	2.84	2.43	2.14	1.94	1.79	1.67	1.58	1.51	1.46
5.2	6.77	4.62	3.56	2.92	2.51	2.23	2.02	1.87	1.76	1.67	1.60	1.54
5.0	6.77	4.72	3.66	3.02	2.60	2.32	2.12	1.97	1.85	1.76	1.69	1.63
4.8	6.77	4.82	3.76	3.12	2.71	2.43	2.22	2.07	1.96	1.87	1.80	1.74
4.6	6.90	4.94	3.88	3.25	2.83	2.55	2.34	2.19	2.08	1.99	1.92	1.86
4.4	7.03	5.08	4.02	3.38	2.97	2.68	2.48	2.33	2.21	2.13	2.05	2.02
4.2	7.19	5.24	4.18	3.54	3.12	2.84	2.64	2.49	2.37	2.28	2.21	2.21
4.0	7.37	5.42	4.36	3.72	3.31	3.02	2.82	2.67	2.55	2.46	2.44	2.44
3.8	7.58	5.63	4.57	3.93	3.52	3.23	3.03	2.88	2.76	2.70	2.70	2.70
3.6	7.83	5.88	4.82	4.18	3.76	3.48	3.28	3.13	3.01	3.01	3.01	3.01
3.4	8.12	6.17	5.11	4.47	4.06	3.77	3.57	3.42	3.38	3.38	3.38	3.38
3.2	8.47	6.52	5.46	4.82	4.40	4.12	3.92	3.81	3.81	3.81	3.81	3.81
3.0	8.89	6.94	5.88	5.24	4.82	4.54	4.34	4.34	4.34	4.34	4.34	4.34
2.8	9.40	7.45	6.39	5.75	5.34	5.05	4.98	4.98	4.98	4.98	4.98	4.98
2.6	10.04	8.09	7.03	6.39	5.97	5.77	5.77	5.77	5.77	5.77	5.77	5.77
2.4	10.84	8.89	7.83	7.19	6.77	6.77	6.77	6.77	6.77	6.77	6.77	6.77

#

## 4. Fire Performance

### Building Code of Australia and Australian Standards

BCA Volume 1 Part C defines the fire resistance requirements for Class 2 to 9 buildings. BCA Volume 2 Part 3.7.1 defines the fire resistance requirements for Class 1 and 10a buildings. Australian Standard AS 3700 sets out the means of determining the fire resistance of masonry, for the three limit states described in the BCA.

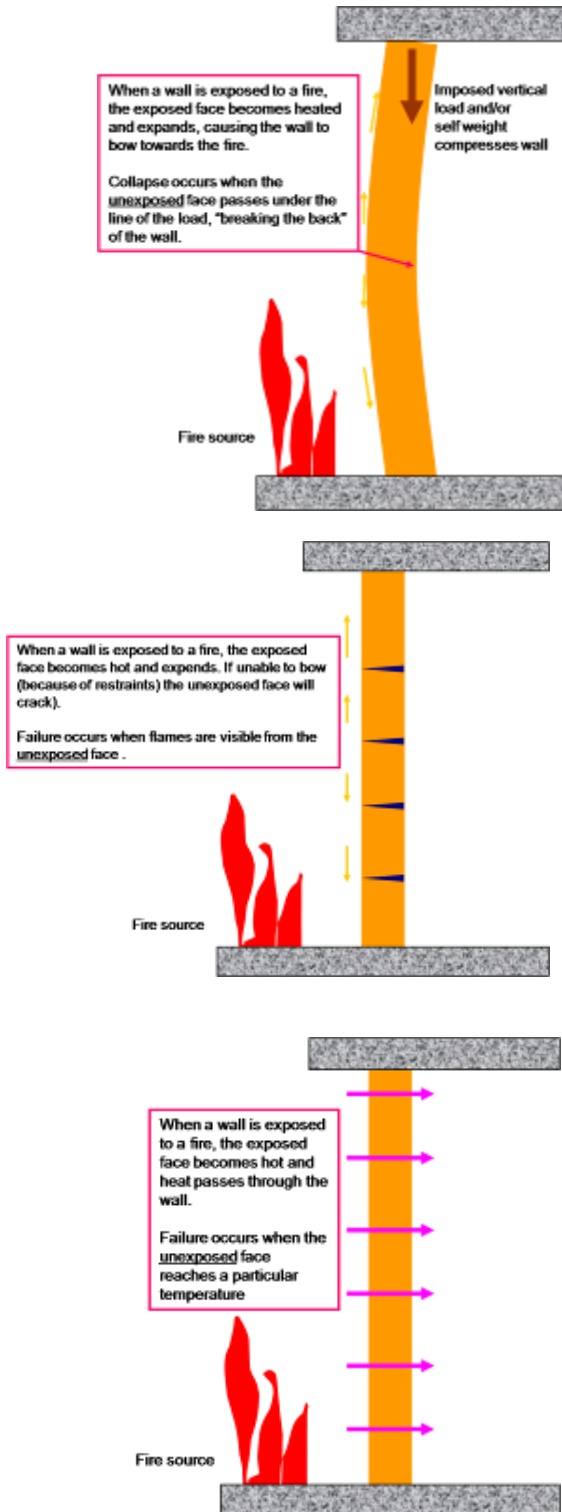

Fire Test to AS 1530.4

The Fire Resistance Level (FRL) for Structural Adequacy is the ability of a wall to remain stable when exposed to fire. Structural Adequacy is a function of:

- Thermal expansion of the material
- Slenderness (affected by thickness, vertical span and horizontal span between supports)
- Reinforcement.

The Fire Resistance Level (FRL) for Integrity is the ability of a wall to resist the passage of flames and hot gasses from one side to the other. Integrity is a function of:

- Material type
- Material thickness

The Fire Resistance Level (FRL) for Insulation is the ability of a wall to resist the passage of heat from one side to the other. Insulation is a function of:

- Material type
- Equivalent thickness
- Render on two sides (if present)

- The material properties may be determined from fire tests to AS 1540.4.
- This information may be then interpreted using the formulae given in AS 3700 or similar standards to predict wall behaviour.

Wall panels may be supported at the top and bottom and subjected to an applied load. This is known as a "loadbearing test". Alternatively the panels may be supported on one side and not subjected to any externally applied load. This is known as a "non-loadbearing test". The terminology is a little misleading, since experience has shown that collapse of a wall (structural adequacy failure) is more influenced by the number of sides supported and the corresponding wall slenderness than by the magnitude of this applied vertical load. A more informative description would be "test with supports at top and bottom" and "test with supports on four sides".

## Kerry Inset photos

The standard fire test in AS 1530.4 uses the same three failure criteria, mentioned in the BCA and AS 3700, of structural adequacy, integrity and insulation.

## Kerry Inset test results and time-temperature curve

Option 1 200 mm wide Unreinforced Walls

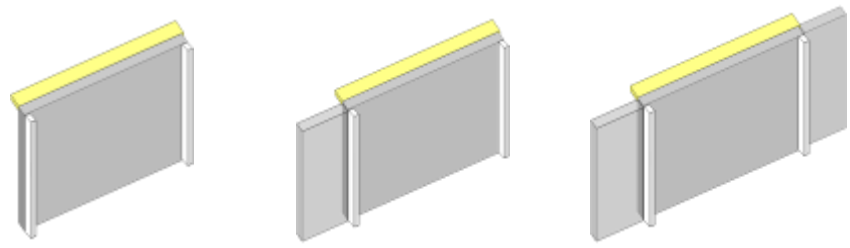
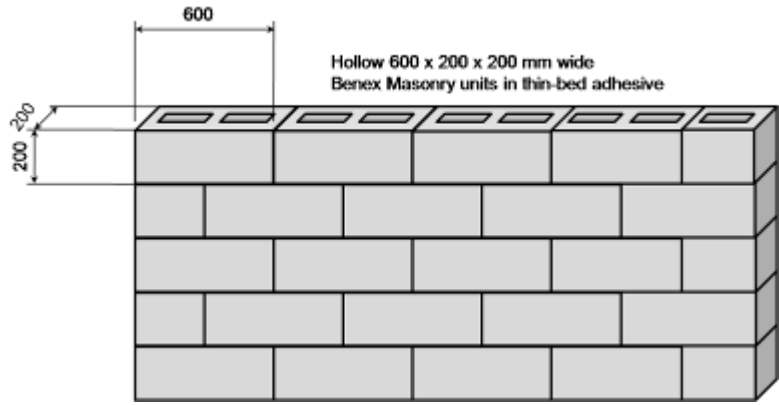

## 200 mm Unreinforced Benex Masonry Fire Resistance Level (Structural Adequacy) in minutes

Vertical robustness coefficient	$C_v$	27.0
Horizontal robustness coefficient	$C_h$	36.0
Vertical fire coefficient	$a_{vf}$	0.75
Horizontal fire coefficient	$a_h$	1.00
Thickness	$t$	200 mm

Height H (m)	Length between vertical supports, L (m)											
	2.4	3.0	3.6	4.2	4.8	5.4	6.0	6.6	7.2	7.8	8.4	9.0
10.0	240	180	30									
9.8	240	180	30	30								
9.6	240	180	60	30								
9.4	240	180	60	30								
9.2	240	180	60	30								
9.0	240	180	60	30								
8.8	240	180	60	30								
8.6	240	180	90	30	30							
8.4	240	180	90	30	30							
8.2	240	180	90	60	30							
8.0	240	240	90	60	30							
7.8	240	240	90	60	30							
7.6	240	240	120	60	30	30						
7.4	240	240	120	90	30	30						
7.2	240	240	180	90	60	30						
7.0	240	240	180	90	60	30						
6.8	240	240	240	90	60	30	30					
6.6	240	240	240	120	60	30	30					
6.4	240	240	240	120	90	60	30					
6.2	240	240	240	180	90	60	30	30				
6.0	240	240	240	180	90	60	30	30				
5.8	240	240	240	240	120	90	60	30				
5.6	240	240	240	240	120	90	60	30	30			
5.4	240	240	240	240	180	90	60	30	30			
5.2	240	240	240	240	180	90	90	60	30	30		
5.0	240	240	240	240	240	120	90	60	30	30	30	30
4.8	240	240	240	240	240	180	90	60	60	30	30	30
4.6	240	240	240	240	240	180	120	90	60	60	60	60
4.4	240	240	240	240	240	240	120	90	90	90	90	90
4.2	240	240	240	240	240	240	180	120	120	120	120	120
4.0	240	240	240	240	240	240	240	180	180	180	180	180
3.8	240	240	240	240	240	240	240	240	240	240	240	240
3.6	240	240	240	240	240	240	240	240	240	240	240	240
3.4	240	240	240	240	240	240	240	240	240	240	240	240
3.2	240	240	240	240	240	240	240	240	240	240	240	240
3.0	240	240	240	240	240	240	240	240	240	240	240	240
2.8	240	240	240	240	240	240	240	240	240	240	240	240
2.6	240	240	240	240	240	240	240	240	240	240	240	240
2.4	240	240	240	240	240	240	240	240	240	240	240	240

## Option 2 – 200 mm wide Reinforced Internal or External Walls

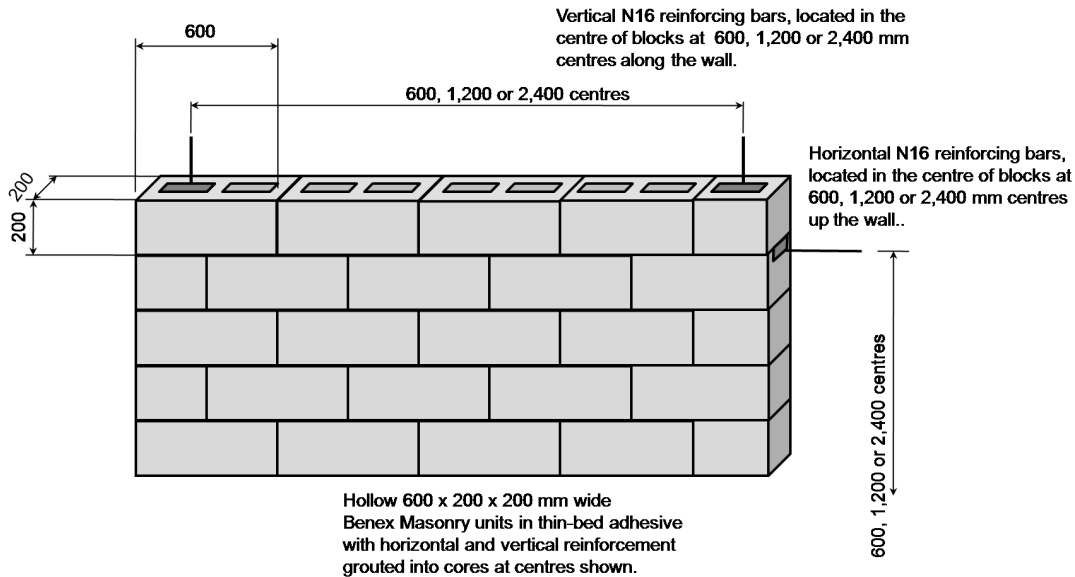

The following table is for 200 mm Reinforced Benex Masonry, supported on all four sides to the structure, i.e. fixed to both columns, a braced strong/stiff top beam, and at the base with connectors designed to transmit the loads to the supports. The designer must determine the design load (kPa) and compare this to the tabulated capacity (kPa).

The masonry must be reinforced in accordance with one of the threeoptions, as follows:

1. N16 horizontal and vertical reinforcement at 2,400 mm centres
2. N16 horizontal and vertical reinforcement at 1,200 mm centres
3. N16 horizontal and vertical reinforcement at 600 mm centres

The following tables are based Benex properties reported in CSIRO Report No DTS767 (dated 30/10/07), and the method used in AS 3700 Section 6, with the following qualifications. Provided the reinforcement and connections to the structural frame are adequate to withstand 0.5 kPa horizontal out-of-plane load, non-loadbearing Benex walls will be suitable for 240 minutes Fire Resistance Level (Structural Adequacy).

**200 mm Benex Masonry, Reinforced Horizontally and Vertically with 1 N16 @ 2,400 mm  
Lateral Load Capacity (kPa)**

Thickness		T 200 mm										
		Length between vertical supports, L (m)										
Height H (m)	2.4	3.0	3.6	4.2	4.8	5.4	6.0	6.6	7.2	7.8	8.4	9.0
10.0	240	240	240	240	240							
9.8	240	240	240	240	240							
9.6	240	240	240	240	240							
9.4	240	240	240	240	240							
9.2	240	240	240	240	240							
9.0	240	240	240	240	240							
8.8	240	240	240	240	240							
8.6	240	240	240	240	240							
8.4	240	240	240	240	240							
8.2	240	240	240	240	240							
8.0	240	240	240	240	240							
7.8	240	240	240	240	240							
7.6	240	240	240	240	240							
7.4	240	240	240	240	240							
7.2	240	240	240	240	240							
7.0	240	240	240	240	240	240	240					
6.8	240	240	240	240	240	240	240					
6.6	240	240	240	240	240	240	240					
6.4	240	240	240	240	240	240	240					
6.2	240	240	240	240	240	240	240	240				
6.0	240	240	240	240	240	240	240	240				
5.8	240	240	240	240	240	240	240	240	240			
5.6	240	240	240	240	240	240	240	240	240	240		
5.4	240	240	240	240	240	240	240	240	240	240	240	
5.2	240	240	240	240	240	240	240	240	240	240	240	240
5.0	240	240	240	240	240	240	240	240	240	240	240	240
4.8	240	240	240	240	240	240	240	240	240	240	240	240
4.6	240	240	240	240	240	240	240	240	240	240	240	240
4.4	240	240	240	240	240	240	240	240	240	240	240	240
4.2	240	240	240	240	240	240	240	240	240	240	240	240
4.0	240	240	240	240	240	240	240	240	240	240	240	240
3.8	240	240	240	240	240	240	240	240	240	240	240	240
3.6	240	240	240	240	240	240	240	240	240	240	240	240
3.4	240	240	240	240	240	240	240	240	240	240	240	240
3.2	240	240	240	240	240	240	240	240	240	240	240	240
3.0	240	240	240	240	240	240	240	240	240	240	240	240
2.8	240	240	240	240	240	240	240	240	240	240	240	240
2.6	240	240	240	240	240	240	240	240	240	240	240	240
2.4	240	240	240	240	240	240	240	240	240	240	240	240

**200 mm Benex Masonry, Reinforced Horizontally and Vertically with 1 N16 @ 1,200 mm  
Lateral Load Capacity (kPa)**

Thickness t 200 mm

**Length between vertical supports, L (m)**

Height H (m)	2.4	3.0	3.6	4.2	4.8	5.4	6.0	6.6	7.2	7.8	8.4	9.0
10.0	240	240	240	240	240	240	240	240	240			
9.8	240	240	240	240	240	240	240	240	240			
9.6	240	240	240	240	240	240	240	240	240			
9.4	240	240	240	240	240	240	240	240	240			
9.2	240	240	240	240	240	240	240	240	240			
9.0	240	240	240	240	240	240	240	240	240			
8.8	240	240	240	240	240	240	240	240	240			
8.6	240	240	240	240	240	240	240	240	240			
8.4	240	240	240	240	240	240	240	240	240			
8.2	240	240	240	240	240	240	240	240	240			
8.0	240	240	240	240	240	240	240	240	240			
7.8	240	240	240	240	240	240	240	240	240			
7.6	240	240	240	240	240	240	240	240	240			
7.4	240	240	240	240	240	240	240	240	240			
7.2	240	240	240	240	240	240	240	240	240			
7.0	240	240	240	240	240	240	240	240	240	240	240	240
6.8	240	240	240	240	240	240	240	240	240	240	240	240
6.6	240	240	240	240	240	240	240	240	240	240	240	240
6.4	240	240	240	240	240	240	240	240	240	240	240	240
6.2	240	240	240	240	240	240	240	240	240	240	240	240
6.0	240	240	240	240	240	240	240	240	240	240	240	240
5.8	240	240	240	240	240	240	240	240	240	240	240	240
5.6	240	240	240	240	240	240	240	240	240	240	240	240
5.4	240	240	240	240	240	240	240	240	240	240	240	240
5.2	240	240	240	240	240	240	240	240	240	240	240	240
5.0	240	240	240	240	240	240	240	240	240	240	240	240
4.8	240	240	240	240	240	240	240	240	240	240	240	240
4.6	240	240	240	240	240	240	240	240	240	240	240	240
4.4	240	240	240	240	240	240	240	240	240	240	240	240
4.2	240	240	240	240	240	240	240	240	240	240	240	240
4.0	240	240	240	240	240	240	240	240	240	240	240	240
3.8	240	240	240	240	240	240	240	240	240	240	240	240
3.6	240	240	240	240	240	240	240	240	240	240	240	240
3.4	240	240	240	240	240	240	240	240	240	240	240	240
3.2	240	240	240	240	240	240	240	240	240	240	240	240
3.0	240	240	240	240	240	240	240	240	240	240	240	240
2.8	240	240	240	240	240	240	240	240	240	240	240	240
2.6	240	240	240	240	240	240	240	240	240	240	240	240
2.4	240	240	240	240	240	240	240	240	240	240	240	240

**200 mm Benex Masonry, Reinforced Horizontally and Vertically with 1 N16 @ 600  
Lateral Load Capacity (kPa)**

Thickness	t      200    mm											
Height H (m)	Length between vertical supports, L (m)											
	2.4	3.0	3.6	4.2	4.8	5.4	6.0	6.6	7.2	7.8	8.4	9.0
10.0	240	240	240	240	240	240	240	240	240	240	240	240
9.8	240	240	240	240	240	240	240	240	240	240	240	240
9.6	240	240	240	240	240	240	240	240	240	240	240	240
9.4	240	240	240	240	240	240	240	240	240	240	240	240
9.2	240	240	240	240	240	240	240	240	240	240	240	240
9.0	240	240	240	240	240	240	240	240	240	240	240	240
8.8	240	240	240	240	240	240	240	240	240	240	240	240
8.6	240	240	240	240	240	240	240	240	240	240	240	240
8.4	240	240	240	240	240	240	240	240	240	240	240	240
8.2	240	240	240	240	240	240	240	240	240	240	240	240
8.0	240	240	240	240	240	240	240	240	240	240	240	240
7.8	240	240	240	240	240	240	240	240	240	240	240	240
7.6	240	240	240	240	240	240	240	240	240	240	240	240
7.4	240	240	240	240	240	240	240	240	240	240	240	240
7.2	240	240	240	240	240	240	240	240	240	240	240	240
7.0	240	240	240	240	240	240	240	240	240	240	240	240
6.8	240	240	240	240	240	240	240	240	240	240	240	240
6.6	240	240	240	240	240	240	240	240	240	240	240	240
6.4	240	240	240	240	240	240	240	240	240	240	240	240
6.2	240	240	240	240	240	240	240	240	240	240	240	240
6.0	240	240	240	240	240	240	240	240	240	240	240	240
5.8	240	240	240	240	240	240	240	240	240	240	240	240
5.6	240	240	240	240	240	240	240	240	240	240	240	240
5.4	240	240	240	240	240	240	240	240	240	240	240	240
5.2	240	240	240	240	240	240	240	240	240	240	240	240
5.0	240	240	240	240	240	240	240	240	240	240	240	240
4.8	240	240	240	240	240	240	240	240	240	240	240	240
4.6	240	240	240	240	240	240	240	240	240	240	240	240
4.4	240	240	240	240	240	240	240	240	240	240	240	240
4.2	240	240	240	240	240	240	240	240	240	240	240	240
4.0	240	240	240	240	240	240	240	240	240	240	240	240
3.8	240	240	240	240	240	240	240	240	240	240	240	240
3.6	240	240	240	240	240	240	240	240	240	240	240	240
3.4	240	240	240	240	240	240	240	240	240	240	240	240
3.2	240	240	240	240	240	240	240	240	240	240	240	240
3.0	240	240	240	240	240	240	240	240	240	240	240	240
2.8	240	240	240	240	240	240	240	240	240	240	240	240
2.6	240	240	240	240	240	240	240	240	240	240	240	240
2.4	240	240	240	240	240	240	240	240	240	240	240	240

## 5. Acoustic Performance

When sound impinges on a wall, it may be reflected or absorbed.

- Reflected sound may manifest in a room as undesirable echoes, and may be controlled by a variety of techniques, including surface treatment and masonry unit design.
- Absorbed sound may be dissipated within the wall, transmitted through or radiated through wall vibration.

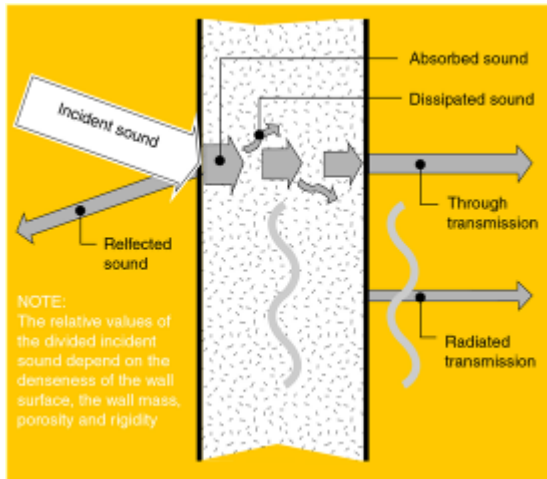

There are three distinct modes of sound transmission through walls:

1. Below the resonant frequency, the stiffness of the wall is of greatest importance, and the mass and damping have little effect. As the frequency increases, the mass of the wall becomes more important and the wall begins to resonate.
2. Beyond resonance, the mass of the wall provides a damping effect, and “high mass” systems have an advantage over lightweight alternatives. The resistance to sound transmission increases by approximately 6 dB for each doubling of the frequency or for each doubling of the mass.
3. Above the critical frequency, the coincidence of the sound waves control the behaviour. The critical frequency for heavy wall systems is relatively low. A coincidence dip immediately above the critical frequency indicates a loss in airborne sound resistance.

### Impact Sound Resistance

When bedrooms or other quiet areas are adjacent to bathrooms, kitchens and the like, it is important to reduce the sound transmitted through the wall as a result of a blow to the other side of the wall or attached furniture. The impact sound resistance of a wall is measured by generating noise with a machine having multiple steel hammers, which impact on a steel plate placed in contact with the wall. The sound passing through the wall may be measured in a manner similar to that used for airborne sound resistance.

Resistance to impact sound requires properties different from those for resistance to airborne sound. A dense stiff material will vibrate when it is struck, while a soft material will simply absorb the blow without transmitting it. For example, hard dense plaster or render has a lower impact sound resistance than the softer commercially available plasterboards. Soft or resilient connections between the external skin and the body of the wall will also reduce the amount of impact that is transmitted. The impact sound resistance of a wall can generally be improved over a bare wall by the use of cladding fixed directly to steel furring channels. The use of resilient impact clips can improve the impact insulation performance over a bare wall by typically 3 dB. The use of free-standing cladding without any attachment to the masonry will provide better results.

## BCA Vol 1 Clause F5.5 Requirements

- Walls that separate sole occupancy units in a Class 2 or 3 building or between two Class 1 buildings
  - $R_w + C_{tr}$  (airborne) not less than 50, and
  - Impact sound resistance, if the wall separates a habitable room in one sole occupancy unit from a bathroom, sanitary compartment, laundry or kitchen of another unit or plant room or lift shaft).
- Walls that separate a sole occupancy unit from a plant room, lift shaft, stairway, public corridor, public lobby or the like in a Class 2 or 3 building:
  - $R_w$  (airborne) not less than 50, and
  - Impact sound resistance, if the wall separates a habitable room in one sole occupancy unit from a plant room, or lift shaft.
- Walls that separates two sole occupancy units or separates a sole occupancy unit from a kitchen, bathroom, sanitary compartment (not en-suite), laundry, plant room or utilities room in a Class 9c aged-care building
  - $R_w$  (airborne) not less than 45, and
  - Impact sound resistance if the wall separates a habitable room in one sole occupancy unit from a kitchen or laundry.
- A door incorporated in a wall that separates a sole occupancy unit from stairway, public corridor, public lobby or the like in a Class 2 or 3 building and a door incorporated in a wall that separates a sole occupancy unit from a kitchen or laundry in a Class 9c aged care building.
  - $R_w$  (airborne) not less than 30.

Walls requiring impact sound resistance shall consist of two leaves separated by a gap of at least 20 mm (and in Class 2 or 3 where required, connected by resilient ties).

## BCA Vol 2 Clauses 3.8.6.1 to 3.8.6.4 Requirements

- Walls that separate a bathroom, sanitary compartment, laundry or kitchen of one Class 1 building from a habitable room (other than a kitchen) in an adjoining Class 1 building (dwelling) shall have:
  - $R_w + C_{tr}$  (airborne) not less than 50 and
  - Discontinuous construction. For cavity walls, a minimum of 20 mm cavity between two separate leaves, which may be connected, if required for structural purposes, with resilient ties. Northern Territory, Queensland and Western Australia have varied this requirement to  $R_w$  not less than 50 and Impact Sound Resistance.
- Walls are required to be detailed in accordance with BCA Vol 2 Clause 3.8.6.3, which make provision for the sealing of sound insulated walls at junctions with perimeter wall and roof cladding. This clause also requires that masonry joints be filled and provides for sound insulated articulation joints. BCA Vol 2 Clause 3.8.6.4 makes provision for services in sound insulated walls.
- Walls required to have a sound insulation shall be constructed to the underside of:
  - a floor above
  - a ceiling with the same acoustic rating
  - a roof above.

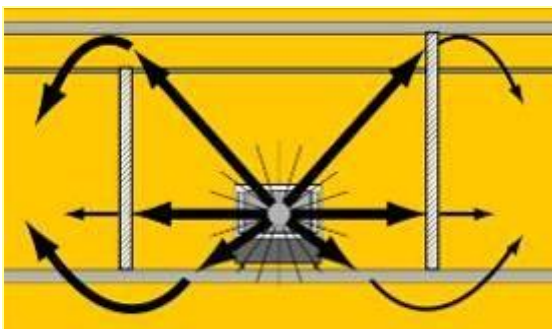

### Effect of Joints and Gaps

Gaps reduce the sound attenuation of a wall. Laboratory tested walls have full joints. Site construction must also have full joints to ensure similar sound attenuation. Gaps around the vertical edges of a wall and at the ceiling will diminish the sound resistance of a wall. A gap 0.1% of wall area (corresponding to a 3 mm gap along the length of a 3 m high wall) can reduce the sound transmission resistance by typically 10-20 dB. Gaps around the periphery of walls should be sealed using a high-density acoustically-rated mastic or similar sealant. Sealants should have a typical density of 1600 kg/m<sup>3</sup>. Sealants should be applied to both faces of the wall and should be applied to a depth equal to the width of the gap. Typical penetrations in walls include mechanical services ducts, refrigerant pipes, hydraulic reticulation lines, waste pipes and fire sprinklers and electrical cables. It is essential to provide an acoustically rated seal around the penetration.

### Surface Treatment

Cladding or render may be applied to masonry walls to assist in achieving required sound attenuation, but should be applied full-height, from floor slab to soffit.

### Chases

Chases in walls diminish the sound attenuation. Chases should not extend deeper than 25mm into the wall. All chases should be rendered over after the pipes or cables are installed.

### Airborne Sound Transmission of Benex Masonry

The following values for Weighted Sound Index and Spectrum Adaption Term may be used for the determination of the performance of Benex Masonry against the criteria of the Building Code of Australia.

In particular, 200 mm hollow Benex Masonry + resilient clips + plasterboard on one side + 100 mm solid Benex Masonry veneer leaf is suitable for BCA Volume 1 Part F5 or BCA Volume 2 Clause 3.8.6, applications that require  $R_w$  50.

Airborne Sound Transmission of Benex Masonry		
System	$R_w$	C; C <sub>tr</sub>
200 mm hollow Benex Masonry	37	-1; -3
200 mm hollow Benex Masonry + Resilient clips + Plasterboard on one side	37	0; -3
200 mm hollow Benex Masonry + Resilient clips + Plasterboard on one side + 100 mm solid Benex Masonry veneer leaf	52	-1; -5

## 6. Thermal Performance

### Factors Affecting Thermal Efficiency

The main factors influencing good solar design are as follows:

- Adequate solar access in cold climates. The building should be oriented such that the warmth can be harnessed in winter, and cooling breezes captured in summer.
- For warm areas, large eaves, verandas, sun-shades and heavy curtains prevent sunshine from entering and overheating a building during hot weather. Good ventilation and light-coloured roofs assist the summer cooling process.
- For temperate and cool areas, north-facing windows permit the entry of winter sun, while correctly proportioned eaves restrict the entry of summer sun. Properly sealed doors and windows allow cross-ventilation in summer and restrict air and heat leakage in winter.
- The inclusion of roof and ceiling insulation, together with wall and floor insulation in some circumstances, will limit heat flows to and from the building. This is further discussed below.
- The thermal mass of tiled roofs, Benex Masonry walls and concrete floors will act as a dampener to heat flows.

### Thermal Performance – Heat Transfer

Heat transfers through the fabric of a building by a combination of:

- Conduction
- Convection
- Radiation.

### Thermal Mass

If a building with high thermal mass experiences a heating and cooling cycle which crosses the comfort zone, the roof, walls and floor will store the heat energy for an extended period, gradually releasing it over time. In winter, high thermal mass buildings will remain relatively warm, while in summer, they will remain relatively cool.

In winter, heat trying to pass through the wall will become trapped in the wall and part will slowly pass back into the room. In summer the reverse occurs. Heat trying to pass through the wall from the outside will become trapped in the wall and part will slowly pass back out of the building. The thermal mass of the member (wall, roof/ceiling, floor etc) is the combination of the properties of each of the components (e.g. Benex Masonry, insulation, foil etc) and is a function of the mass and specific heat.

### Kerry add illustration of Benex Wall

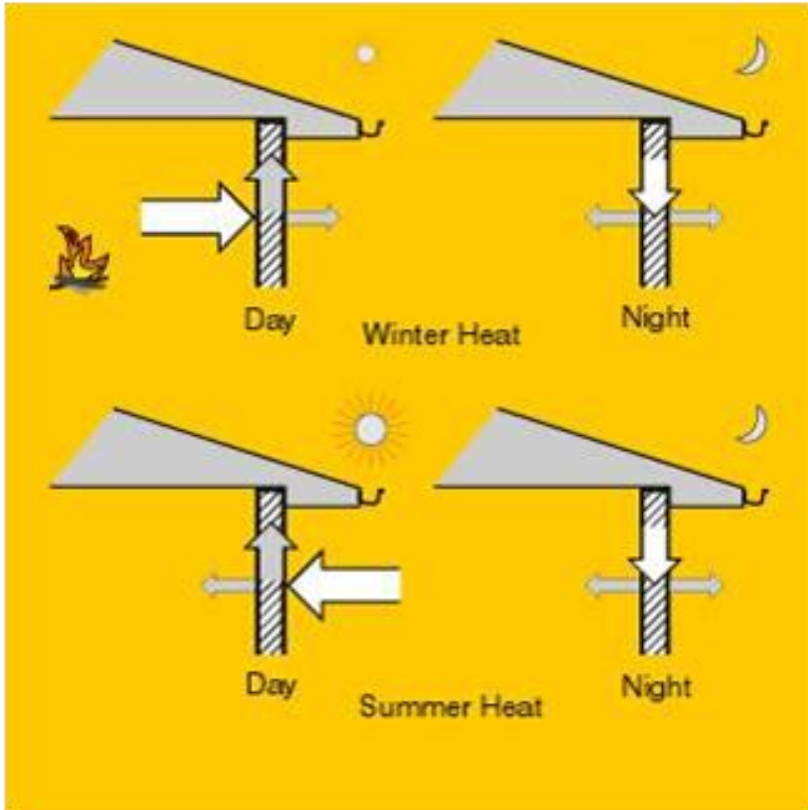

### The calculations below are in accordance with the BCA Deemed-to-Satisfy provisions for reflective air spaces, and the published R value of 0.25 for Aircell Insulbreak 80. (See Aircell Website page) Kerry will contact Steve Oliver from Aircell 1/11/08

## Thermal Resistance of Benex Masonry External Walls

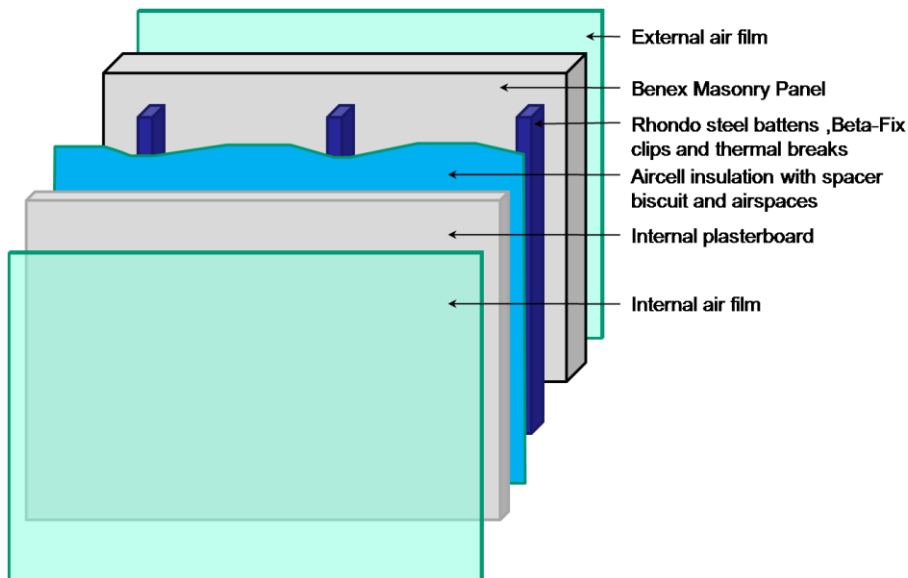

### Thermal Properties – Benex Masonry

Material	External thickness mm	Thermal resistance, R m <sup>2</sup> .K/W
External air film		0.03
200 mm Benex Masonry (ET 112)	200	0.36
Internal air film		0.12
<b>Total</b>	<b>200</b>	<b>0.52</b>
External air film		0.03
200 mm Benex Masonry (ET 112)	200	0.36
Air space	38	<b>0.17</b>
Internal plasterboard	10	0.06
Internal air film		0.12
<b>Total</b>	<b>248</b>	<b>0.74</b>
External air film		0.03
200 mm Benex Masonry (ET 112)	200	0.36
Air space	20	0.50
Aircell Insulbreak 80		0.25
Air space	20	0.48
Internal plasterboard	10	0.06
Internal air film		0.12
<b>Total</b>	<b>280</b>	<b>1.80</b>

#### Notes

This table provides the thermal resistance of Benex Masonry single leaf walls and Benex Masonry veneer walls, without added insulation.

Thermal resistance of 200 mm Benex Masonry is based on BRANZ Test Report EC 1310, 4/5/07.

Aircell Insulbreak 80 provides both insulation and thermal break..

## 7. Detailing

### Introduction

All buildings are required to be built such that:

- The assumed support for walls (and other members) can be achieved, to resist gravity, wind, earthquake, and other loads;
- The building is weatherproof; and
- The structure is durable, able to resist salts or any other expected corrosive materials.

### Structural Supports

The connections and supporting structure must have sufficient combined capacity to transmit the horizontal in-plane and out-of-plane loads from the wall to the supports. They must also be such that the assumed action of the wall panel can be achieved. For example, if two-way action has been assumed, the connections at the top, bottom and each side must be consistent with the assumed support configuration.

The “connection” calculations in Appendix C provide a guide to the determination of the connection capacities. For top, base and sides, the connection capacities may be provided by a combination of:

- Masonry Bond and Friction (friction will not be applicable for side supports); and/or
- Steel Starter Bars, set in concrete slabs or columns; and/or
- Other Connectors, such as proprietary ties.

### Weather-Proofing

Buildings must be constructed such that they are weather proof. Benex Masonry (including its units and joints) resist the ingress of water, as set out in the CSIRO report below. If required, the weatherproofing may be enhanced by paint specifications complying with AS 3700. Associated structures, such as concrete slabs and footings, should be correctly designed and detailed to restrict movement. The masonry should be protected against rising damp, and the tops of masonry walls should be protected by flashings.

#### Ingress of Water through the Benex Masonry and Joints

CSIRO Report No DTS767 (30/10/07) paragraph 5.05 states that properly built Benex Masonry walls can resist the conditions imposed by the ASTM water permeability test for more than 24 hours, without failure. In general, rendered Benex Masonry walls can be considered as impervious without further protection since any tiny holes in mortar joints can be fully covered with render.

#### Masonry Should Not Crack

Notwithstanding the fact that walls constructed of Benex Masonry are impervious to moisture penetration (as per the statement above), it is necessary to ensure that the walls are properly supported on footings or other structures, which have adequate strength and stiffness to limit movement that would cause the Benex Masonry to crack. Such movement generally results from foundation expansion or contraction, thermal expansion and contraction, wind, earthquake or imposed loads.

Moisture movements in clay or similar soils result in expansion and contraction, causing the building to either “hog” or “sag”. Trees roots suck the moisture out of the soil causing it to shrink. Poor or badly maintained drainage systems allow a build up of moisture in the soil causing it to expand. Unreinforced masonry may crack sympathetically with deflected concrete footings, and the inclusion of articulation joints will control the position and width of cracks. In a wall exposed to the weather, articulation joints must incorporate flexible sealants, which should be regularly inspected and maintained.

The incorporation of reinforcement into Benex Masonry walls will assist resistance to cacking in the most extreme cases of foundation movement.

### Maintenance

Buildings should be regularly maintained, to ensure that:

- Trees have not grown too close to the footings;
- The plumbing system does not leak; and
- The stormwater drainage system effectively removes rainwater

### **Durability**

#### Masonry Units

Masonry units, which may be subject to salt attack, must have salt resistance, determined in accordance with AS/NZS 4456.10. CSIRO Report No DTS767 (30/10/07) paragraph 5.14 states that both solid and hollow Benex blocks can be categorised as “Exposure Grade” as per AS/NZS 4456.10:1997, and that they can be used in aggressive environments such as “severe marine environments” and “aggressive soils”, as per AS 3700 Clause 5.2.5. The report notes that salt diffusion occurs only through open (cut) surfaces, and that capped surfaces seem impermeable towards salt movement.

#### Built-In Components

AS 3700 Table 5.1 defines the required classifications for masonry units, mortar, built-in components and cover for reinforcement or tendons for the particular environments and positions within the structure. Ties, connectors and lintels should be galvanized to the required thicknesses. In aggressive environments, they should be manufactured from stainless steel or other non-corrosive materials in accordance with AS/NZS 2699.1, AS/NZS 2699.2 or AS/NZS 2699.3. Testing criteria for components in categories R0 to R4 are quite severe:

- (a) Maximum temperature of 55°C or 40°C if the component is embedded.
- (b) Daily temperature cycles from ambient (18°C) to 40°C.
- (c) The medium surrounding the accessory being initially alkaline pH up to 10 but reducing over time to become not less than 10 (i.e. close to neutral).
- (d) Remaining wet for a 3 month period.
- (e) Aerosol penetration to an extent depending on distance from the coast:
  - R0 - Nil
  - R1 - 10 g/m<sup>2</sup>/day
  - R2 - 20 g/m<sup>2</sup>/day
  - R3 - 60 g/m<sup>2</sup>/day
  - R4 - 300 g/m<sup>2</sup>/day
- (f) Exposure to ultra-violet radiation of 20 MJ/m<sup>2</sup> for a period of up to 4 weeks corresponding to the period of construction.

#### Concrete Grout

Concrete grout, which protects reinforcement, must have sufficient cement content to create an alkaline environment which lasts the duration of the design life. Concrete grout must include 300 kg/m<sup>3</sup> of portland cement content to provide an alkaline environment, which must surround steel reinforcement and any other embedded metal items.

#### Reinforcement

Unlike conventional masonry, Benex Masonry incorporates thin-bed adhesive in lieu of relatively permeable cement-based mortar joints. This feature, together with impermeable blocks, means that the risk of corrosion of both horizontal and vertical reinforcement is significantly reduced. Benex Masonry incorporates flush-ended masonry units. These should be rebated to allow reinforcement to pass through the perpendicular joint. The <sup>1</sup>reinforcement should be supported off the webs in such a way that the cover requirements can be achieved over the whole length of the reinforcement.

---

<sup>1</sup> See section on “Weatherproofing”.

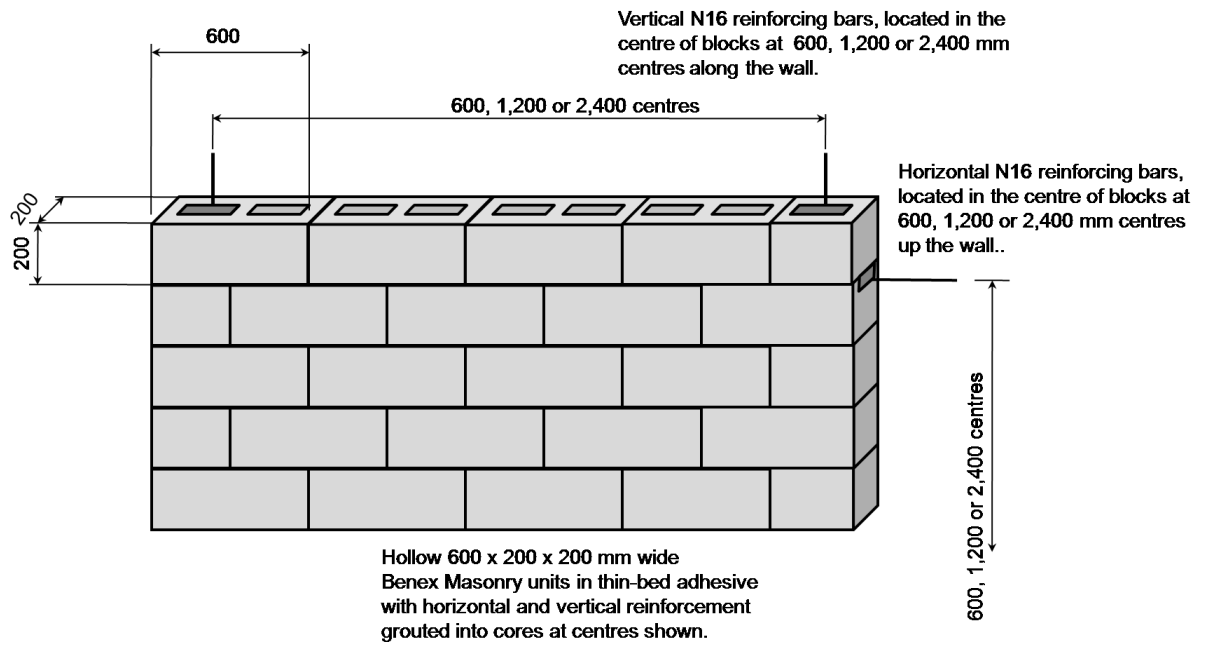

**Detail of Standard Reinforcement in 200 mm Hollow Benex Masonry**

Kerry will give new drawings

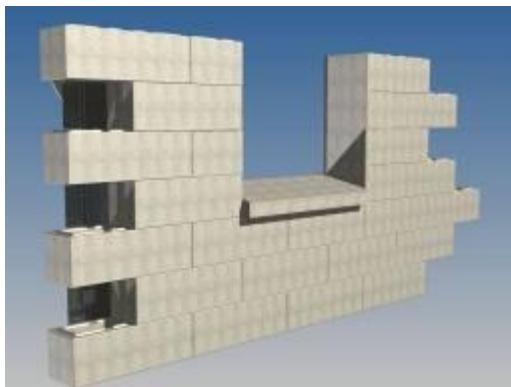

**Typical Sill Arrangement**

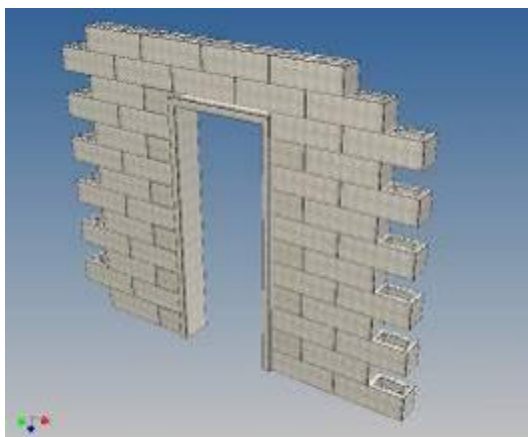

**Typical Door Frame Arrangement**

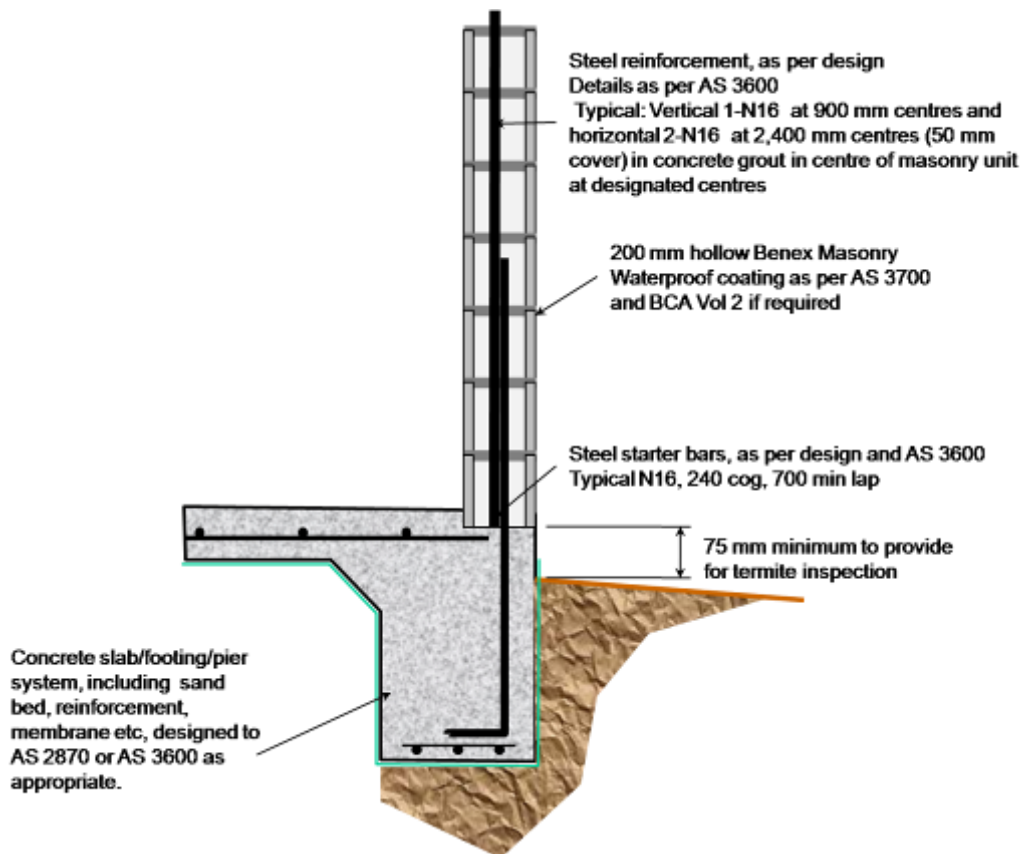
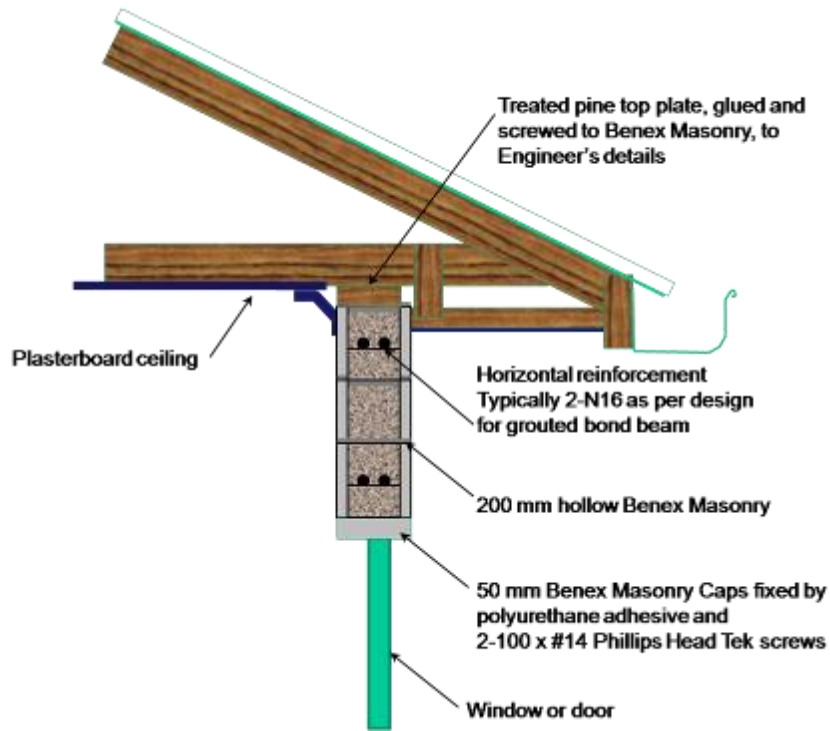

**Typical Details**  
**200 mm Hollow Reinforced Benex Masonry (Unlined)**

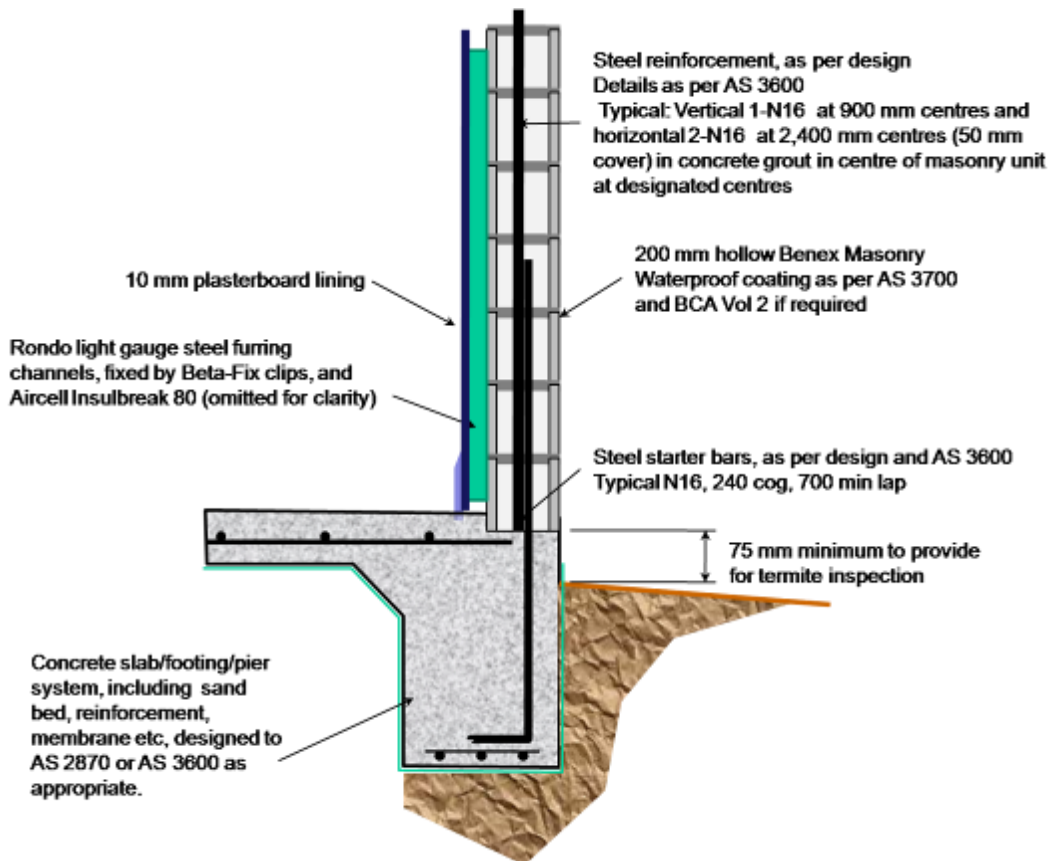
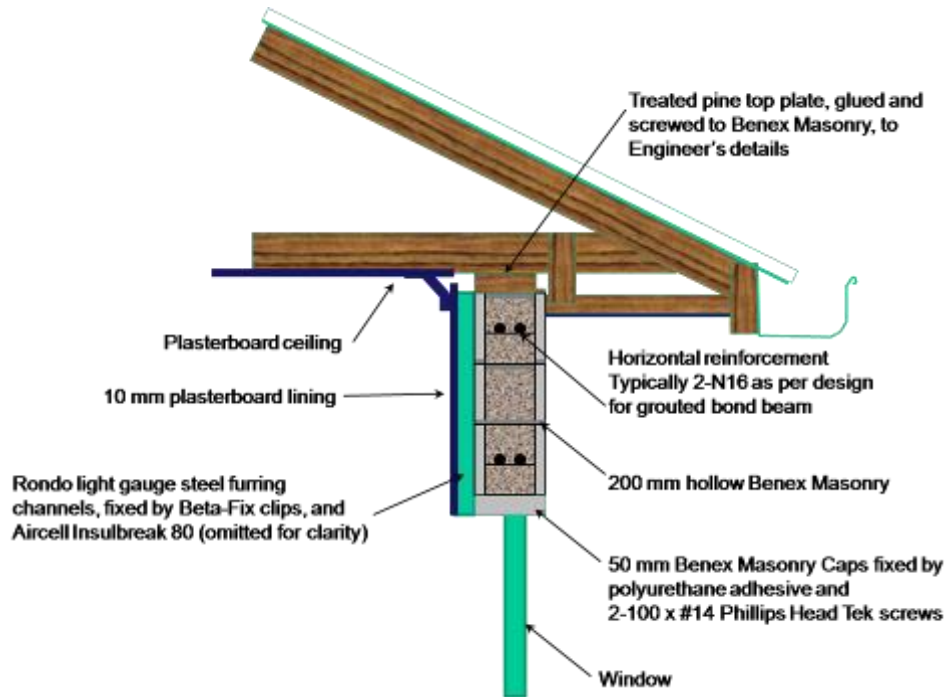

**Typical Details**  
**200 mm Hollow Reinforced Benex Masonry (Plasterboard Lined & Insulated)**

## 8. Specifications

### Introduction

The building design and construction process involves three principle functions:

- Design, including product selection;
- Manufacture and supply of all components; and
- Construction, including the attendant supervision, inspections and certification.

### Design

The design process must encompass the selection of the appropriate product for the particular design application. The Architect and Engineer for any building project share responsibility (and authority) to determine and communicate the design (within the constraints of Building Code of Australia) to the builders. They are required to consider all relevant matters affecting the building and its components, and determine their designs drawing on professional training, experience, peer practices, ethics, client requirements, published standards, research and the like. Building Code of Australia DTS (Deemed-to-Satisfy) provisions play an important part in this decision making (and in many cases will be adopted by the Engineer or Architect), although there are also many cases where the Engineer or Architect may specify details that are different from these. This information is communicated to builders by Drawings and Specifications.

### Manufacture and supply

There are two principal requirements of manufacturers.

- Ensure that the Company has a properly functioning Management System, capable of delivering consistent product and service to predetermined specifications. Substantial compliance with the provision of AS/NZS ISO 9001 is considered to be an indicator of such a properly functioning system.
- Ensure that the nominated products satisfy the requirements of nominated Building Code of Australia clauses.

### Construction

Construction shall be carried out by authorised Benex installers. It shall faithfully ensure that the design expectations have been met, and that the product has been installed in accordance with the manufacturer's instructions. However, the Builder and the Contractors must assume responsibility for the quality of the construction work.

Designers often take it for granted that builders and tradesmen understand the detailed requirements for the construction of good quality buildings. This is not so - They need to be clearly guided by competent and informed designers.

### Specification Template

Appendix H sets out a Specification Template for Benex Masonry, also available in electronic format that may be adapted and edited for particular projects.<sup>2</sup>

---

<sup>2</sup> To download electronic specifications, click on [www.benex.com](http://www.benex.com)

# Kerry to reconsider and/or delete Section 9 ?

## 9. Sustainability

### Sustainability Policy

Benex Technologies is committed to encouraging the use of sustainable building products, with a view to:

- Reducing green-house gas generation, which causes global warming;
- Reducing the use of non-renewable resources upon which our society depends; and
- Reducing land, water or air pollution or degradation, which alienates the use of these resources.

### Embodied Energy and Heating and Cooling Energy – Housing Applications

The BCA (Building Code of Australia) sets out the performance requirements for energy saving in Australian buildings, and some DTS (deemed-to-satisfy) forms of construction. Both the performance requirements and the DTS provisions are based on minimising heating and cooling energy, and do not give requirements for minimising the embodied energy used to manufacture the building components.

Appendix 9 provides estimates of the embodied energy used to manufacture Benex Masonry wall systems, and compares it to a selected benchmark (clay masonry veneer), commonly used in Australian housing. From this data, the savings in embodied energy to change from the benchmark system to Benex Masonry can be calculated, and this information can be expressed as a percentage of the heating and cooling energy over the life of the house.

- The analysis shows that the embodied energies of Benex Masonry Single Leaf wall system (with grouted cores at 2.4 m centres) consumes slightly more embodied energy and Benex Masonry Veneer wall system consumes slightly less embodied energy than the selected benchmark construction (clay masonry veneer).
- The analysis also shows that the small changes (positive or negative) in embodied energy, resulting from changing construction from the clay brick veneer benchmark to Benex Masonry, are insignificant when compared with the target operational 5 Star heating and cooling energy expended over the life of the building.

# Appendix A Benex Masonry Applications

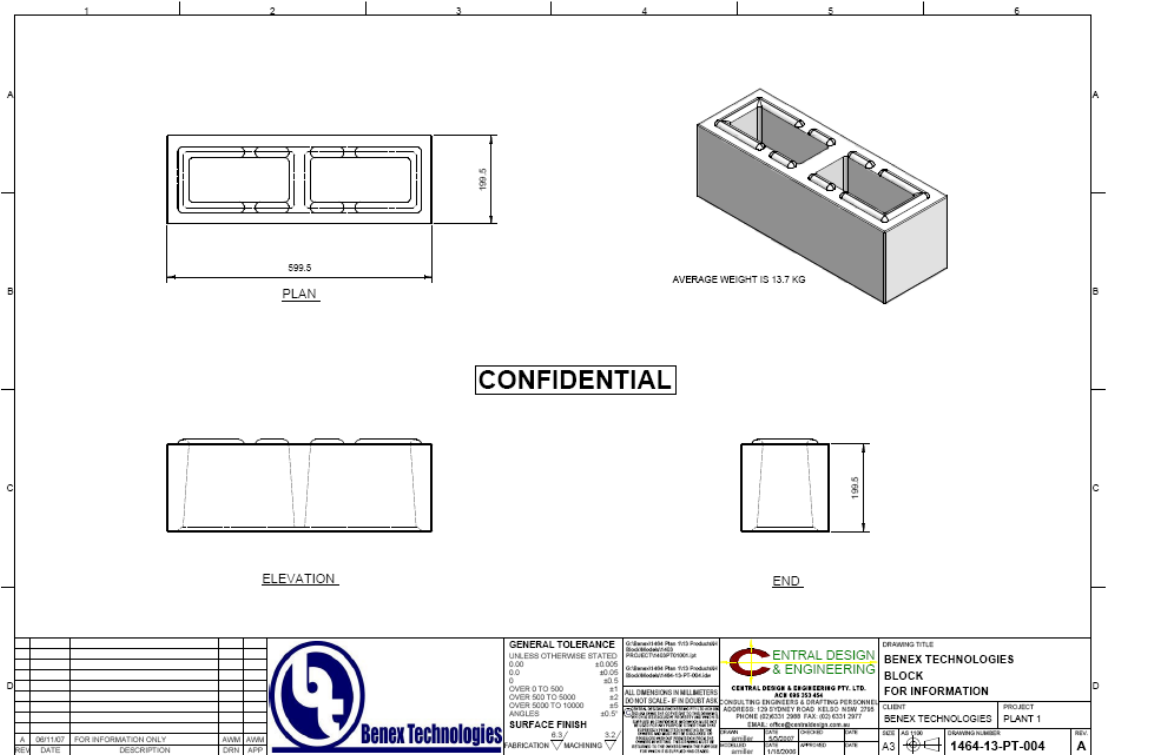
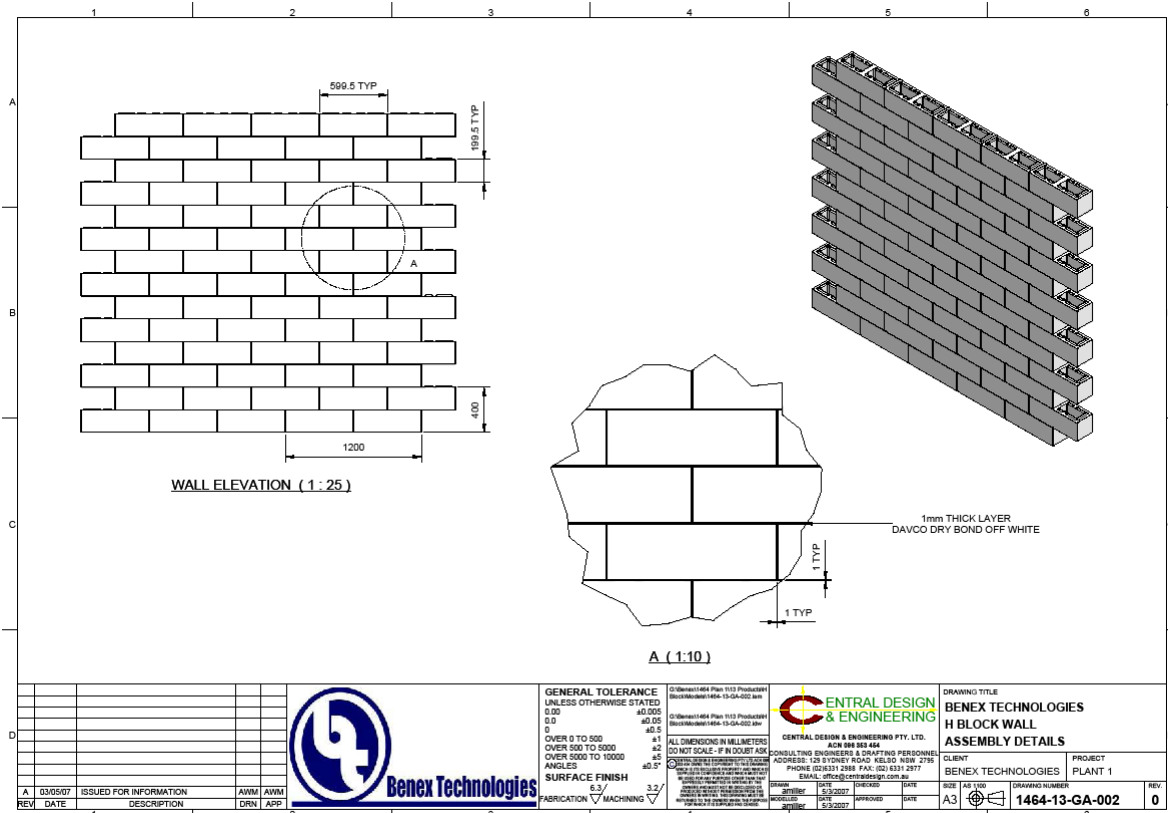

## Kerry to supply new drawing

## Appendix B

# Building Code of Australia Compliance

### Scope

Benex Masonry is outside the scope of the most relevant referenced document, AS 3700, its use must be treated as an Alternative Solution. This appendix sets out the Building Code of Australia clauses used to establish the basis of the "Alternative Solution".

### Building Code of Australia Volume 1 (Class 2 – 9 Buildings)

The following clauses of Building Code of Australia Volume 1 provide the criteria upon which this manual is based.

#### Clause A0.4 Compliance with the Building Code of Australia

##### Requirement

*A Building Solution will comply with the Building Code of Australia if it satisfies the Performance Requirements*

##### Application

In this case, the opinion is based on complying with this clause.

#### Clause A0.5 Meeting the Performance Requirements

##### Requirement

*Compliance with the Performance Requirements can only be achieved by-*

- (a) *complying with the Deemed-to-Satisfy Provisions; or*
- (b) *formulating an Alternative Solution, which:*
  - (i) *complies with the Performance requirements; or*
  - (ii) *is shown to be at least equivalent to the Deemed-to-Satisfy Provisions; or*
- (c) *a combination of (a) and (b)*

##### Application

In this case, the opinion is based on:

- (b) *formulating an Alternative Solution, which:*
  - (i) *complies with the Performance requirements; or*
  - (ii) *is shown to be at least equivalent to the Deemed-to-Satisfy Provisions; or*

#### Clause A0.8 Meeting the Performance Requirement

##### Requirement

- (a) *An Alternative Solution must be assessed according to one or more of the Assessment Methods.*
- (b) *An Alternative Solution will only comply with the Building Code of Australia if the Assessment Methods used to determine compliance with the Performance Requirements have been satisfied.*
- (c) *The Performance Requirements relevant to an Alternative Solution must be determined in accordance with A0.10.*

##### Application

In this case, the opinion is based on the Alternate Solutions complying fully with this clause.

#### Clause A0.9 Assessment Methods

##### Requirement

*The following Assessment Methods, or any combination of them, can be used to determine that a Building Solution complies with the Performance Requirements:*

- (a) Evidence to support that the use of a material, form of construction or design meets a Performance Requirement or a Deemed-to-Satisfy Provision as described in A2.2.
- (b) Verification Methods such as—
  - (i) the Verification Methods in the Building Code of Australia; or
  - (ii) such other Verification Methods as the appropriate authority accepts for determining compliance with the Performance Requirements.
- (c) Comparison with the Deemed-to-Satisfy Provisions.
- (d) Expert Judgment.

#### Application

In this case, the opinion is based on compliance with paragraphs:

- (a) Evidence to support that the use of a material, form of construction or design meets a Performance Requirement or a Deemed-to-Satisfy Provision as described in A2.2.
- (b) Verification Methods such as—
  - (i) the Verification Methods in the Building Code of Australia; or
  - (ii) such other Verification Methods as the appropriate authority accepts for determining compliance with the Performance Requirements.
- (c) Comparison with the Deemed-to-Satisfy Provisions.

### Clause A0.10 Relevant Performance Requirements

#### Requirement

*In order to comply with the provisions of A1.5 (to comply with Sections A to J inclusive) the following method must be used to determine the Performance Requirement or Performance Requirements relevant to the Alternative Solution:*

- (a) Identify the relevant Deemed-to-Satisfy Provision of each Section or Part that is to be the subject of the Alternative Solution.
- (b) Identify the Performance Requirements from the same Sections or Parts that are relevant to the identified Deemed-to-Satisfy Provisions.
- (c) Identify Performance Requirements from other Sections and Parts that are relevant to any aspects of the Alternative Solution proposed or that are affected by the application of the Deemed-to-Satisfy Provisions, that are the subject of the Alternative Solution.

#### Application

In this case, the opinion is based on full compliance with this paragraph.

### Clause A2.1 Suitability of materials

#### Requirement

*Every part of a building must be constructed in an appropriate manner to achieve the requirements of the Building Code of Australia, using materials that are fit for purpose for which they are intended.*

#### Application

In this case, the opinion is based on [calculation that the Benex Masonry satisfies this criterion.](#)

### Clause A2.2 Evidence of suitability

#### Requirement

- (a) Subject to A2.3 and A2.4, evidence to support that the use of a material, form of construction or design meets a Performance Requirement or Deemed-to-Satisfy Provision may be in the form of one or a combination of the following:
  - (i) A report issued by a Registered Testing Authority, showing that the material or form of construction has been submitted to the tests listed in the report, and setting out the results of those tests and any other relevant information that demonstrates its suitability for use in the building.....

- (iii) *A certificate from a professional engineer or other appropriately qualified person which-*
  - (A) *certifies that a material, design or form of construction complies with the requirements of the Building Code of Australia; and*
  - (B) *sets out the basis on which it is given and the extent to which relevant specification, rules, codes of practice or other publication have been relied upon.*
- (iv) *A current certificate issued by a product certification body that has been accredited by the Joint Accreditation System of Australia and New Zealand (JAS-ANZ).....*
- (b) *Any copy of documentary evidence submitted, must be a complete copy of the original report or document.*

**Application**

In this case, the opinion is based on the following:

Reference to reports issued by a registered testing authority as per paragraph (i). The reports shall be checked to ensure that they are complete, as per paragraph (b).

**Specification A1.3 Documents Adopted by Reference**  
**Table 1 Schedule of Referenced Documents**

**Application**

The following referenced documents, called up in Building Code of Australia Vol 1-2007 Table 1, provide the source documents used to: *Identify the relevant Deemed-to-Satisfy Provision, Identify the Performance Requirements and Identify Performance Requirements from other Sections and Parts that are affected by the application of the Deemed-to-Satisfy Provisions*

*AS 3700-2001 Including Amendments 1, 2 and 3.*

## Particular Criteria Relating to Building Code of Australia Volume 1 (Class 2 to 9 Buildings)

### Section B - Structure

#### Performance Requirement

##### BP1.1

- (a) A building or structure, to the degree necessary, must—
- (i) remain stable and not collapse; and
  - (ii) prevent progressive collapse; and
  - (iii) minimise local damage and loss of amenity through excessive deformation, vibration or degradation; and
  - (iv) avoid causing damage to other properties, by resisting the actions to which it may reasonably be subjected.

##### BP1.2

The structural resistance of materials and forms of construction must be determined using five percentile characteristic material properties with appropriate allowance for—

- (a) known construction activities; and
- (b) type of material; and
- (c) characteristics of the site; and
- (d) the degree of accuracy inherent in the methods used to assess the structural behaviour; and
- (e) action effects arising from the differential settlement of foundations, and from restrained dimensional changes due to temperature moisture, shrinkage, creep and similar effects.

#### State Variations

Nil

#### Compliance

Compliance with these performance requirements is set out in Section 4 and Appendix C of this manual, which incorporate the findings of CSIRO Report No DTS767 (31/10/07) and consideration of AS 3700-2001.

### Section C - Fire Resistance

#### Performance Requirement

##### CP1

A building must have elements which will, to the degree necessary, maintain structural stability during a fire appropriate to—

- (a) the function or use of the building; and
- (b) the fire load; and
- (c) the potential fire intensity; and
- (d) the fire hazard; and
- (e) the height of the building; and
- (f) its proximity to other property; and
- (g) any active fire safety systems installed in the building; and
- (h) the size of any fire compartment; and
- (i) fire brigade intervention; and
- (j) other elements they support; and
- (k) the evacuation time.

##### CP2

- (a) A building must have elements which will, to the degree necessary, avoid the spread of fire—

- (i) to exits; and
  - (ii) to sole-occupancy units and public corridors; and
- Application:  
CP2(a)(ii) only applies to a Class 2 or 3 building or Class 4 part.
- (iii) between buildings; and
  - (iv) in a building.

- (b) Avoidance of the spread of fire referred to in (a) must be appropriate to—

- (i) the function or use of the building; and

- (ii) the fire load; and
- (iii) the potential fire intensity; and
- (iv) the fire hazard; and
- (v) the number of storeys in the building, and
- (vi) its proximity to other property; and
- (vii) any active fire safety systems installed in the building; and
- (viii) the size of any fire compartment; and
- (ix) fire brigade intervention; and
- (x) other elements they support; and
- (xi) the evacuation time.

#### CP3

A building must be protected from the spread of fire and smoke to allow sufficient time for orderly evacuation of the building in an emergency.

Application:

CP3 only applies to-

- (a) a patient care area of a Class 9a health-care building; and
- (b) a Class 9c aged care building.

#### CP4

A material and an assembly must, to the degree necessary, resist the spread of fire to limit the generation of smoke and heat, and any toxic gases likely to be produced, appropriate to—

- (a) the evacuation time; and
- (b) the number, mobility and other characteristics of occupants; and
- (c) the function or use of the building; and
- (d) any active fire safety systems installed in the building.

#### CP5

A concrete external wall that could collapse as a complete panel (eg. tilt-up and pre-cast concrete) must be designed so that in the event of fire within the building the likelihood of outward collapse is avoided.

Limitation:

CP5 does not apply to a building having more than two storeys above ground level.

#### CP6

A building must have elements, which will, to the degree necessary~ avoid the spread of fire from service equipment having—

- (a) a high fire hazard; or
- (b) a potential for explosion resulting from a high fire hazard.

#### CP7

A building must have elements, which will, to the degree necessary, avoid the spread of fire so that emergency equipment provided in a building will continue to operate for a period of time necessary to ensure that the intended function, of the equipment is maintained during a fire.

#### State Variations

Nil

#### Compliance

Compliance with these performance requirements is set out in Section 5 and Appendix D of this manual, which incorporate the findings of CSIRO Report No FSV 1266 (8/6/07), CSIRO Certificate of Test No 2042 and consideration of AS 3700-2001.

**Section F - Health and Amenity – Damp and Weatherproofing**Performance Requirement**FP1.4**

A roof and external wall (including openings around windows and doors) must prevent the penetration of water that could cause—

- (a) unhealthy or dangerous conditions, or loss of amenity for occupants; and
- (b) undue dampness or deterioration of building elements.

*Limitation: FP1.4 does not apply to-*

- (a) Class 7 or 8 buildings where in the particular case there is no necessity for compliance; or
- (b) a garage, tool shed, sanitary compartment or the like, forming a building used for other purposes; or
- (c) an open spectator stand or open-deck carpark.

State Variations

Nil

Compliance

Compliance with these performance requirements is set out in Section 5 and Appendix D of this manual, which incorporate the findings of CSIRO Reports No JK13ATS3468 (9/7/07 and 10/7/07) and CSIRO Report No DTS767 (31/10/07).

**Section F - Health and Amenity (Sound)**Performance Requirement**FP5.2**

Walls separating sole-occupancy units or a sole-occupancy unit from a plant room, lift shaft, stairway, public corridor, public lobby, or the like, or parts of a different classification, must provide insulation against the transmission of—

- (a) airborne sound; and
- (b) impact generated sound, if the wall is separating a bathroom, sanitary compartment, laundry or kitchen in one sole-occupancy unit from a habitable room (other than a kitchen) in an adjoining unit, sufficient to prevent illness or loss of amenity to the occupants.

*Application:*

*FP5.2 only, applies to a Class 2 or 3 building.*

**FP5.5**

Walls separating sole-occupancy units, or a sole-occupancy unit from a kitchen bathroom, sanitary compartment (not being an associated ensuite), laundry, plant room or utilities room, must provide insulation against the transmission of—

- (a) airborne sound; and
- (b) impact generated sound, if the wall separates a sole-occupancy unit from a kitchen or laundry, sufficient to prevent illness or loss of amenity to the occupants.

*Application*

*FP5.5 only applies to a Class 9c aged care building.*

State Variations

Nil

Compliance

Compliance with these performance requirements is set out in Section 6 and Appendix E of this manual, which incorporate the findings of CSIRO Report No TL474 (21-22/3/07).

**Section J Energy and Efficiency****Requirement****J1.5 (a) Walls**

*Deemed-to-Satisfy Provisions from BCA Vol 1 J1.3.(a)*

**State Variations**

*In New South Wales BCA Volume 1 Section J is replaced by NSW Section J.*

- *For Class 2 and Class 4 buildings, NSW BASIX applies in accordance with NSW Subsection JA.*
- *For Class 3, 5, 6, 7a, 7b, 9a, 9b and 9c buildings, BCA Volume 1 Section J, in accordance with NSW Subsection JB.*

*In Northern Territory, BCA Volume 1 Section J does not apply.*

*In Victoria, there is a variation of the star requirements for JV1.*

**Compliance**

Compliance with these performance requirements is set out in Section 7 and Appendix F of this manual, which incorporate the findings of BRANZ Report No EC1310 JC0951 (4/5/07).

**Building Code of Australia Volume 2 (Class 1 and 10 Buildings)**

The following clauses of Building Code of Australia Volume 2 provide the criteria upon which this manual is based.

**Clause 1.0.4 Compliance with the Building Code of Australia**

## Requirement

*A Building Solution will comply with the Building Code of Australia if it satisfies the Performance Requirements*

## Application

In this case, the opinion is based on complying with this clause.

**Clause 1.0.5 Meeting the Performance Requirements**

## Requirement

*Compliance with the Performance Requirements can only be achieved by-*

- (a) *complying with the Deemed-to-Satisfy Provisions; or*
- (b) *formulating an Alternative Solution, which:*
  - (i) *complies with the Performance requirements; or*
  - (ii) *is shown to be at least equivalent to the Deemed-to-Satisfy Provisions; or*
- (c) *a combination of (a) and (b)*

## Application

In this case, the opinion is based on:

- (b) *formulating an Alternative Solution, which:*
  - (i) *complies with the Performance requirements; or*
  - (ii) *is shown to be at least equivalent to the Deemed-to-Satisfy Provisions; or*

**Clause 1.0.8 Meeting the Performance Requirements**

## Requirement

- (a) *An Alternative Solution must be assessed according to one or more of the Assessment Methods.*
- (b) *An Alternative Solution will only comply with the Building Code of Australia if the Assessment Methods used to determine compliance with the Performance Requirements have been satisfied.*
- (c) *The Performance Requirements relevant to an Alternative Solution must be determined in accordance with 1.0.10.*

## Application

In this case, the opinion is based on the Alternate Solutions complying fully with this clause.

**Clause A0.9 Assessment Methods**

## Requirement

*The following Assessment Methods, or any combination of them, can be used to determine that a Building Solution complies with the Performance Requirements:*

- (a) *Evidence to support that the use of a material, form of construction or design meets a Performance Requirement or a Deemed-to-Satisfy Provision as described in 1.2.2.*
- (b) *Verification Methods such as—*
  - (i) *the Verification Methods in the Building Code of Australia; or*
  - (ii) *such other Verification Methods as the appropriate authority accepts for determining compliance with the Performance Requirements.*
- (c) *Comparison with the Deemed-to-Satisfy Provisions.*
- (d) *Expert Judgment.*

## Application

In this case, the opinion is based on compliance with paragraphs:

- (a) *Evidence to support that the use of a material, form of construction or design meets a Performance Requirement or a Deemed-to-Satisfy Provision as described in A2.2.*
- (b) *Verification Methods such as—*
  - (i) *the Verification Methods in the Building Code of Australia; or*
  - (ii) *such other Verification Methods as the appropriate authority accepts for determining compliance with the Performance Requirements.*
- (c) *Comparison with the Deemed-to-Satisfy Provisions.*

**Clause A0.10 Relevant Performance Requirements**

## Requirement

*The following method must be used to determine the Performance Requirement or Performance Requirements relevant to the Alternative Solution:*

- (a) *Identify the relevant Deemed-to-Satisfy Provision of Section 3 that is to be the subject of the Alternative Solution.*
- (b) *Identify the Performance Requirements from Section 2 that are relevant to the identified Deemed-to-Satisfy Provisions.*
- (c) *Identify Performance Requirements from Section 2 that are relevant to any aspects of the Alternative Solution proposed or that are affected by the application of the Deemed-to-Satisfy Provisions, that are the subject of the Alternative Solution.*

## Application

In this case, the opinion is based on full compliance with this paragraph.

**Clause 1.2.1 Suitability of materials**

## Requirement

*Every part of a building must be constructed in an appropriate manner to achieve the requirements of the Housing Provisions, using materials that are fit for purpose for which they are intended.*

## Application

In this case, the opinion is based on calculation that the Benex Masonry satisfies this criterion.

**Clause 1.2.2 Evidence of suitability**

## Requirement

- (a) *Subject to 1.2.3 and 1.2.4, evidence to support that the use of a material, form of construction or design meets a Performance Requirement or Deemed-to-Satisfy Provision may be in the form of one or a combination of the following:*
  - (i) *A report issued by a Registered Testing Authority, showing that the material or form of construction has been submitted to the tests listed in the report, and setting out the results of those tests and any other relevant information that demonstrates its suitability for use in the building.....*
  - (iii) *A certificate from a professional engineer or other appropriately qualified person which-*
    - (A) *certifies that a material, design or form of construction complies with the requirements of the Building Code of Australia; and*
    - (B) *sets out the basis on which it is given and the extent to which relevant specification, rules, codes of practice or other publication have been relied upon.*

- (iv) *A current certificate issued by a product certification body that has been accredited by the Joint Accreditation System of Australia and New Zealand (JAS-ANZ).....*
- (b) *Any copy of documentary evidence submitted, must be a complete copy of the original report or document.*

Application

In this case, the opinion is based on the following:

- Reference to reports issued by a registered testing authority as per paragraph (i). The reports shall be checked to ensure that they are complete, as per paragraph (b).

**Specification 1.4.1**

**Table 1.4.1 Schedule of Referenced Documents**

Application

The following referenced documents, called up in Building Code of Australia Vol 2 Table 1.4.1, provide the source documents used to: *Identify the relevant Deemed-to-Satisfy Provision, Identify the Performance Requirements and Identify Performance Requirements from other Sections and Parts that are affected by the application of the Deemed-to-Satisfy Provisions ...*

*AS 3700-2001 Including Amendments 1, 2 and 3.*

## Particular Criteria Relating to Building Code of Australia Volume 2 (Class 1 & 10 Buildings)

### Part P2.1 Structure

#### Performance Requirement

- (a) *A building or structure, to the degree necessary, must—*
- (i) *remain stable and not collapse; and*
  - (ii) *prevent progressive collapse; and*
  - (iii) *minimise local damage and loss of amenity through excessive deformation, vibration or degradation; and*
  - (iv) *avoid causing damage to other properties, by resisting the actions to which it may reasonably be subjected.*
- (c) *The structural resistance of materials and forms of construction must be determined using five percentile characteristic material properties with appropriate allowance for—*
- (i) *known construction activities; and*
  - (ii) *type of material; and*
  - (iii) *characteristics of the site; and*
  - (iv) *the degree of accuracy inherent in the methods used to assess the structural behaviour; and*
  - (v) *action effects arising from the differential settlement of foundations, and from restrained dimensional changes due to temperature moisture, shrinkage, creep and similar effects.*

#### State Variations

Nil

#### Compliance

Compliance with these performance requirements is set out in Section 4 and Appendix C of this manual, which incorporate the findings of CSIRO Report No DTS767 (31/10/07) and consideration of AS 3700-2001.

### Part 2.3 Fire Safety

#### Performance Requirement

##### *P2.3.1 Protection from the spread of fire*

- (a) *A Class 1 building must be protected from the spread of fire from—*
- (i) *another building other than an associated Class 10 building; and*
  - (ii) *the allotment boundary, other than a boundary adjoining a road or public space.*
- (see Figure 2.3.1)*
- (b) *A Class 10a building must not significantly increase the risk of fire spread between Class 2 to 9 buildings.*

#### State Variations

Nil

#### Compliance

Compliance with these performance requirements is set out in Section 5 and Appendix D of this manual, which incorporate the findings of CSIRO Report No FSV 1266 (8/6/07), CSIRO Certificate of Test No 2042 and consideration of AS 3700-2001.

### Part 2.2.2 Weatherproofing and Part 2.2.3 Dampness

#### Performance Requirement

##### *P2.2.2 Weatherproofing*

*A roof and external wall (including openings around windows and doors) must prevent the penetration of water that could cause—*

- (a) *unhealthy or dangerous conditions, or loss of amenity for occupants; and*
- (b) *undue dampness or deterioration of building elements.*

*Limitation: P2.2.2(a) does not apply to Class 10 building except where its construction contributes to the weatherproofing of the Class 1 building*

#### State Variations

Nil

#### Compliance

Compliance with these performance requirements is set out in Section 5 and Appendix D of this manual, which incorporate the findings of CSIRO Reports No JK13ATS3468 (9/7/07 and 10/7/07) and CSIRO Report No DTS767 (31/10/07).

### **P2.4.6 Sound insulation**

#### Performance Requirement

- (a) *Walls separating dwellings must provide insulation against the transmission of airborne sound sufficient to prevent illness or loss of amenity to the occupants.*

#### State Variations

*In Northern Territory P2A.6 is replaced with the following:*

#### *P2.4.6 Sound insulation*

- (a) *Walls separating dwellings must provide insulation against the transmission of airborne and impact generated sound sufficient to prevent illness or loss of amenity to the occupants.*

#### Compliance

Compliance with these performance requirements is set out in Section 6 and Appendix E of this manual, which incorporate the findings of CSIRO Report No TL474 (21-22/3/07). Compliance with the Northern Territory variation requiring impact sound resistance is not claimed.

### **3.12 Energy Efficiency**

#### Acceptable construction practice

*Deemed-to-Satisfy Provisions from BCA Vol 2 3.12.*

#### State variations

In New South Wales BCA Volume 1 Section J is replaced by NSW Section J.

- For Class 2 and Class 4 buildings, NSW BASIX applies in accordance with NSW Subsection JA.
- For Class 3, 5, 6, 7a, 7b, 9a, 9b and 9c buildings, BCA Volume 1 Section J, in accordance with NSW Subsection JB.

In Northern Territory, BCA Volume 1 Section J does not apply.

#### Compliance

Compliance with these performance requirements is set out in Section 7 and Appendix F of this manual, which incorporate the findings of BRANZ Report No EC1310 JC0951 (4/5/07).

## Appendix C Structural Design

### Introduction

This appendix should be read in conjunction with Section 3 Structural Design, for which it provided background and explanation. The design tables in that section are based on the method set out below.

### Benex Masonry Unit Geometry

Benex Masonry units are supplied in two common sizes, whose principle dimensions are:

#### 200 mm Hollow

The principle unit is 600 mm long x 200 mm high x 200 mm wide, with large cores (such that it is classified as “hollow”), and an interlocking system for fixing with “thin-bed” adhesive.. Half-length units are also available.

The unit face shell width,  $t_{su}$ , is 35 mm, although a face shell bedding surface,  $t_s$ , of 25 mm is used for purposes of calculating lateral modulus of rupture of the units, the bedded area for vertical compressive capacity and the bedded area for flexure of reinforced masonry. Based on the CSIRO report, two 25 mm face shell bedding surfaces are used for purposes of calculating vertical bending strength, horizontal bending strength, and the associated wall flexure capacities.

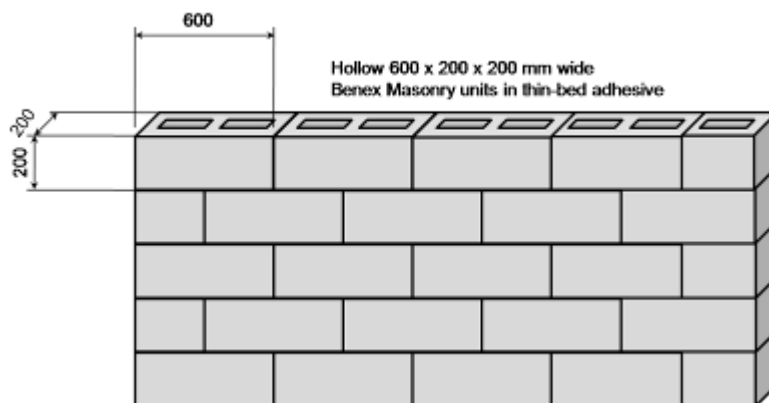

The formulae for determining section properties are given below:

$$\text{Net area of section, } A_b = 2 t_{s_u} \cdot 10^3$$

$$\text{Section modulus of the perpendicular joints, } Z_p = 1,000 t_u^2 / 6 \cdot [6 (t_s / t_u) - 12 (t_s / t_u)^2 + 8 (t_s / t_u)^3]$$

$$\text{Section modulus of the units, } Z_u = 1,000 t_u^2 / 6 \cdot [6 (t_{s_u} / t_u) - 12 (t_{s_u} / t_u)^2 + 8 (t_{s_u} / t_u)^3]$$

$$\text{Section modulus of the bedding surface } Z_d = 1000 t_u^2 / 6 \cdot [6 (t_s / t_u) - 12 (t_s / t_u)^2 + 8 (t_s / t_u)^3]$$

Notes:

1. The recommended values are “per metre” run of joint, and do not take into account the fact that the units and joints alternate. This is for consistency with AS 3700. This fact is considered in the calculation of the horizontal moment capacity, using an approach consistent with AS 3700. CSIRO Report DTS767

adopts an alternative approach (described in Point 3 below), but the end result is identical.

2. For the section modulus of the perpendicular joints, CSIRO Report DTS767 Page 54 reports 1,927,083 mm<sup>3</sup>/m for 200 mm hollow units (based on two 25 mm wide face shell perpendicular joints). This value is half the value recommended in this design example, since it takes into account the fact that perpendicular joints and units alternate in stretcher bond. This fact is considered elsewhere in the recommended design.
3. For the section modulus of the units, the value reported for design is 4,836,000 mm<sup>3</sup>/m for 200 mm hollow units (based on two 35 mm wide face shell).
4. For the section modulus of the bedding surface, CSIRO Report DTS767 Page 54 reports 2,417,916 mm<sup>3</sup>/m for 200 mm hollow units (based on two 35 mm wide face shells). This value is half the value recommended in this design example, since it takes into account the fact that perpendicular joints and units alternate in stretcher bond. This fact is considered elsewhere in the recommended design.

### Robustness

The test programs described in this manual indicate that Benex Masonry walls should be designed in accordance with the requirements of AS 3700. Notwithstanding the requirement to design for loads in the Standards, it is possible for the lateral loads on some walls to be neglected. For example, internal loadbearing basement walls of an apartment building may not be required to be designed for wind, fire or earthquake. However it is possible for all three loads, as well as vehicle impact, to impinge on the basement walls.

The robustness provisions are a practical means of providing an upper limit on the dimensions of walls and isolated piers, thus ensuring that unreasonably large spans are not specified. They are not a substitute for rational design for calculated loads, but rather a global limit beyond which even the most lightly loaded walls and piers should not be built. The robustness provisions must not be used to justify structures which would otherwise fail to meet the design for calculated loads. Close consideration must be given to chasing and the consequent reduction in support.

AS 3700-1998 Clause 4.6 sets out the required robustness limits and has been interpreted as follows in the preparation of this manual.

#### Unreinforced Benex Masonry

- (a) Isolated piers  
 $H / t_r \leq C_v$  ..AS 3700 Equation 4.6.2(1)  
 The transition from an isolated pier to a wall occurs at a height to length ratio of 5:1  
 ..AS 3700 Clause 1.5.2.27
- (b) Vertically spanning walls  
 $H / k_t t_r \leq C_v$  ..AS 3700 Equation 4.6.2(2)
- (c) Walls with at least one edge vertically supported and  $L_r / t_r \leq C_h$   
 $H / t_r = \text{No limit}$  ..AS 3700 Equation 4.6.2(3)
- (d) Walls with at least one edge vertically supported and  $L_r / t_r > C_h$   
 $H / t_r \leq C_v + C_h / (L_r - C_h t_r)$  Equation 4.6.2(4)

For walls with openings, the length for robustness calculations  $L_r$  is measured from any vertical support to the centre line of the opening. This is **not** the same length as the one used to calculate the slenderness for vertical load capacity.

#### Reinforced Benex Masonry and Mixed Construction

For vertically reinforced Benex Masonry walls (vertically reinforced cores at centres less than 2.0 m horizontally and without effective horizontal reinforcement), the robustness limit from Table 4.2 for vertically reinforced masonry can be used and applied to Equation 4.6.2.(2).

Benex Masonry may incorporate bond-beams (horizontally reinforced masonry members). The vertical robustness limit for horizontally reinforced bond beams (i.e. mixed construction with no vertical reinforcement) of "No limit" will apply provided  $L_r/t_r \leq C_h$  (Where  $C_h$  is the value for horizontally reinforced masonry).  $C_h = 36$ . The unreinforced masonry which is contiguous with the reinforced masonry must also be checked for robustness.

For reinforced Benex Masonry walls with both horizontal and vertical reinforcement at centres less than 2.0 m in each direction, the robustness limits from Table 4.2 for both horizontally and vertically reinforced masonry can be used and applied to Equation 4.6.2.(4). For mixed construction with vertical reinforcement (vertically reinforced cores at centres greater than 2.0 m horizontally and without effective horizontal reinforcement), the robustness limit from Table 4.2 for vertically reinforced isolated piers,  $C_v = 36$ , has been used and applied to Equation 4.6.2.(2) except in the case where the wall supports a concrete slab. In this case,  $C_v = 36$  has been used to be consistent with the case of an unreinforced wall supporting a concrete slab. The unreinforced masonry which is contiguous with the reinforced masonry should also be checked for robustness.

### **Characteristic Unconfined Compressive Strength of Benex Masonry Units**

The compressive strength of a unit is its ability to resist crushing. The unit is placed in a compression testing machine, loaded until it fails, and the unconfined compressive strength is calculated. Solid or cored units must be fully bedded in the test and the compressive strength calculated using the full bed area. Hollow units must be bedded only on the face shells, and the compressive strength calculated using the face shell area. An aspect ratio factor is applied to account for the confining effect the machine platens on short wide units, such as bricks. AS 3700 requires the designer to include, on the drawings, the required characteristic compressive strength of the units. CSIRO Report DTS767 Page 27 reports values of 4.92 MPa for 200 mm hollow units (based on two 35 mm wide face shell beds). This manual recommends the specification of 4.0 MPa, thus giving approximately 20% manufacturing tolerance on strength.

### Characteristic Lateral Modulus of Rupture of Benex Masonry Units

Lateral Modulus of Rupture is a measure of the horizontal flexural strength of masonry units. If the lateral modulus of rupture of units is too low, a wall could crack vertically when subjected to horizontal out-of-plane loads such as a wind or earthquake. CSIRO Report DTS767 Page 79 reports 1.52 MPa for 200 mm hollow units. This is above the default value of 0.80 MPa in AS 3700 Clause 1.5.2.9, which states, “....In the absence of test data, the value of ( $f_{ur}$ ) is not allowed to exceed 0.8 MPa.” AS 3700 is interpreted such that the use of the CSIRO test data for lateral modulus of rupture of units does not invoke a classification as “special masonry” with the associated requirements for site testing. This manual is based on 1.5 MPa.

### Characteristic Compressive Strength of Benex Masonry

The compressive strength of masonry is its ability to resist crushing. It is also the basic property used in the design of reinforced masonry for flexure. Stack bonded masonry piers, of at least three units high with joints, are crushed in a compression testing machine until the units split, and the unconfined compressive strength is calculated. CSIRO Report DTS767 Page 78 reports  $0.74 f_{uc}$  for 200 mm hollow units (for use with two 35 mm wide face shell beds).

### Characteristic Flexural Tensile Strength of Benex Masonry

The flexural tensile strength of masonry is the ability of the thin-bed adhesive and block to adhere to each other, thus providing bending resistance. It is tested using a bond wrench to break off units from a stack bonded masonry piers. AS 3700 Clause 3.3.3 permits the use of a characteristic flexural strength of 0.2 MPa for conventional mortars complying with Table 10.1. CSIRO Report DTS767 Page 78 reports 0.27 MPa for 200 mm hollow units (based on two 35 mm wide face shell beds). This is above the default value of 0.20 MPa for normal masonry in AS 3700 Clause 3.3.3. By adopting  $f_{mt} = 0.20$  MPa, the requirement for site testing associated with “special masonry” is avoided.

### Characteristic Shear Strength of Benex Masonry

The shear strength of masonry is its ability to resist splitting under the action of principal tensile stresses caused by shearing across a plane within the masonry. CSIRO Report DTS767 Page 79 reports 0.33 MPa (in-plane) and 0.33 MPa (out-of-plane) for 200 mm hollow units. A maximum value of 0.35 MPa will be used, subject to the conditions imposed by AS 3700 Clause 3.3.4. By adopting 0.35 MPa, it will not be necessary to invoke a classification as “special masonry” with the associated requirements for site testing. CSIRO Report DTS767 Page 79 notes that the capacity reducing factor,  $\phi$ , is applicable in each case. This will be applied during the calculation of the member capacity, consistent with the principles of AS 3700.

### Compressive Capacity of Benex Masonry

According to CSIRO Report DTS767, the compressive capacity of Benex Masonry may be determined in accordance with AS 3700 Clause 7.3, suitably modified to account for the characteristic compressive strength of masonry described above. It is reasonable to assume that this applies equally to both unreinforced masonry (which was tested) and reinforced masonry (which was not tested), provided the reinforcement is ignored. The appropriate formulae are:

$$\text{Basic compressive strength capacity, } F_o = \phi_c (f_m A_b + k_c (f_{cg} / 1.3)^{0.5} A_c) / 1000$$

Vertical slenderness coefficient,  $a_v$

No top support - 2.5

Partial top support, laterally restrained & partially rotationally restrained at bottom - 1.5

Laterally restrained at top and bottom, no rotational restraint - 1.0

Laterally restrained at top and bottom, partially rotationally restrained at one - 0.85

Laterally restrained, partially rotationally restrained at top and bottom - 0.75

Horizontal slenderness coefficient,  $a_h$

Laterally supported at both vertical ends 1.0

Laterally supported at one vertical end 2.5

$$\text{Slenderness for refined calculation, } S_r = \text{MIN}(a_v H / (k_t t_w), 0.7 (a_v H a_h \text{IF}(L_o > 0, L_t, L))^{0.5} / t_w)$$

Eccentricity at the top,  $e_1$  must be determined in accordance with AS 3700 Clause 7.3.

Eccentricity at the base,  $e_2$  must be determined in accordance with AS 3700 Clause 7.3.

Eccentricity ratio at the top of the wall,  $e_1/t_w$

Reduction factor (for eccentricity and slenderness),  $k_{e,s}$   
 $= \text{IF}(e_1/t_w > 0.499, 0, \text{MAX}(0, \text{MIN}(1, \text{IF}(e_1/t_w > 0.05, 0.5(1+e_2/e_1)*((1-2.083e_1/t_w)-(0.025-0.037e_1/t_w)(1.33S_r-8))+0.5(1-0.6 e_1/t_w)(1-e_2/e_1)(1.18-0.03S_r) 1.18 - 0.03 S_r ))))$

Reduction factor (for eccentricity and slenderness),  $k_{crush}$   
 = For "Solid/Cored" units,  $1 - 2 e_1/t_w$  ,  
 For "Hollow" units,  $\text{MIN}( (1 - t_s / t_w ) / (1 - t_s / t_w + 2 e_1/t_w) , (1 - 2 e_1/t_w) / (2 t_s / t_w) )$

Reduction factor (for eccentricity, slenderness and crushing),  $k = \text{MIN}(k_{e,s}, k_{crush})$

Design compressive strength,  $k F_o = k F_o$

### Bending Capacity of Unreinforced Benex Masonry

The bending capacity of unreinforced Benex Masonry may result from either:

- One-way vertical bending (spanning between top and base supports); or
- Two-way bending (spanning between two vertical and two horizontal supports, and incorporating both vertical and horizontal bending capacity).

CSIRO Report DTS767 Page 78 provides a design method, similar to that in AS 3700 Clause 7.4.4.3, that is suitable for designing unreinforced Benex Masonry walls, without openings, for out-of-plane bending, accounting for the characteristic lateral modulus of rupture and flexural bond strength of masonry described above. If it is intended that the wall should include openings, it is necessary to support the edges of the opening by external supports, or by a reinforced cores. Refer to the later section on Reinforced Masonry. The calculated vertical bending capacity of the wall is contingent on the vertical compressive stress induced by any external loading. The appropriate formulae are:

Vertical compressive unfactored stress due to external load (unfactored vertical permanent line load),  $f_{dt} = 1,000 W_{pv} / A_b$

Vertical compressive unfactored self-weight stress at mid height,  $f_{dsm} = \rho H \square t_e 9.81 / (2 A_b 10^6)$

Vertical compressive unfactored self-weight stress at base,  $f_{dsb} = \rho H \square t_e 9.81 / (A_b 10^6)$

Vertical compressive unfactored stress at mid height of wall,  $f_{dm} = f_{dt} + f_{dsm}$

Vertical compressive unfactored stress at base of wall,  $f_{db} = f_{dt} + f_{dsb}$

Bending moment capacity factor,  $k_{mt} = 1.0$

Perpend spacing factor,  $k_p = \text{MIN}(s_p/t_u, s_p/h_u, 1.0)$

For 200 mm hollow units,

$$\text{Vertical bending moment capacity, } M_{cv} = \text{MIN} (\phi_b k_{mt} f'_{mt} Z_d + f_{dm} Z_d, 3 \phi_b k_{mt} f'_{mt} Z_d) / 10^6 \\ = 0.580 \text{ kN.m/m (for zero external vertical load)}$$

$$\text{Horizontal bending moment capacity, } M_{ch} = \phi_b (0.3 f'_{ut} Z_u/2 + 0.7 f'_{mt} Z_p/2) / 10^6 \\ = 0.823 \text{ kN.m/m}$$

$$\text{Lateral load capacity for two-way action, } \phi w_{d2b} = 15 (b_v M_{cv} / H^2 + b_h M_{ch} / L^2) H / L \cdot 10^6$$

### Bending Capacity of Reinforced Benex Masonry

CSIRO Report DTS76 does not provide a design method for reinforced Benex Masonry. However, it does provide the basic properties of Benex Masonry for use in AS 3700 Section 8. Therefore, it is both reasonable and conservative to use AS 3700 Section 8 to design reinforced Benex Masonry. The appropriate formulae are:

$$\text{Width of masonry contributing to the compression face, } b = \text{min} ([4 \cdot t_u + B_i], B)$$

$$\text{Average shear width of each masonry member, } b_w$$

$$\text{Reinforcement strength grade, } f_{sy,m}$$

$$\text{Main reinforcement shear strength (dowel action), } f_{sv} = 17.5 \text{ MPa}$$

$$\text{Depth to the centroid of the tensile steel from the compression face, } d$$

$$\text{Area of all main tensile reinforcement bars in the member, } A_{st}$$

$$\text{Design area of main tensile reinforcement, } A_{sd} = \text{min} [0.29 (1.3 f'_m) b d / f_{sy}, A_{st}]$$

$$\text{Shear capacity, } \phi_r V = \phi_r (f'_{vm} b_w d + f_{vs} A_{st} + f_{sv} A_{sv} d / s)$$

$$\text{Bending moment capacity, } \phi_r M = \phi_r f_{sy} A_{sd} d [1 - 0.6 f_{sy} A_{sd} d / (1.3 f'_m b d)]$$

### In-plane Shear Capacity of Unreinforced Benex Masonry with Pre-compression

CSIRO Report DTS767 Page 79 provides a design method for determining the shear capacity of unreinforced Benex Masonry walls. The appropriate formulae are:

For 200 mm hollow units, where  $A_b$  is the bedded area based on face shell bedding:

$$\text{In-plane shear capacity, } \phi V = A_b (0.3 \phi + 0.5 f_d)$$

## Worked Example

The purpose of the following worked example is to provide guidance to structural engineers on the structural design considerations. The design process is based on AS 3700, with appropriate values reflecting the Benex Masonry's properties.

### Brief

Using both unreinforced and reinforced Benex Masonry, determine the load capacities of the principal external walls (3.8 m high to top support x 6.6 m long between steel portal frames) building subject to lateral wind load and supporting a concrete slab. The wall does not have an opening.

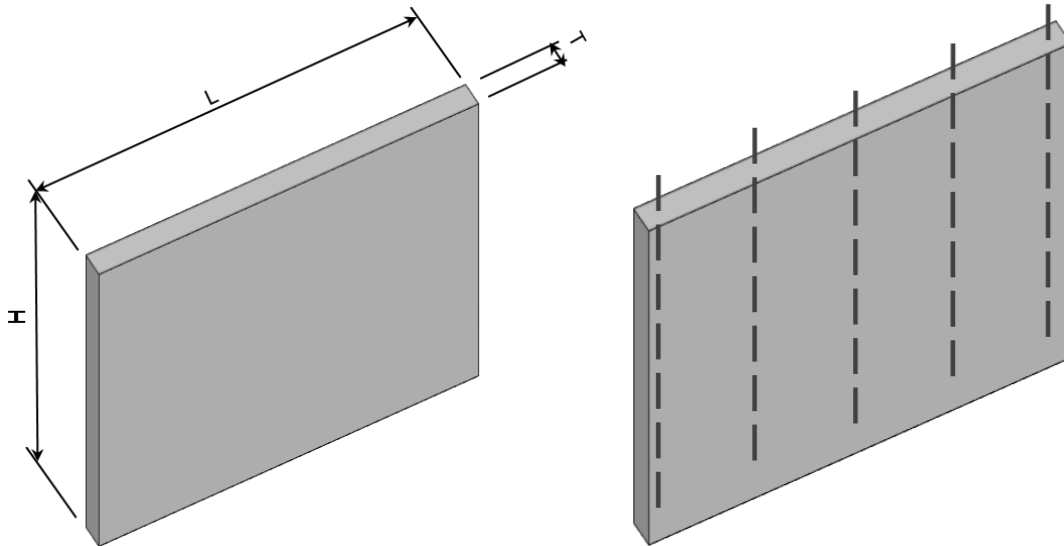

### Wall Dimensions

Height of wall (or pier)  
 H = 3,800 mm

Length of wall (or pier)  
 L = 6,600 mm

Thickness of wall (or pier)  
 T = 200 mm

### Wall Support

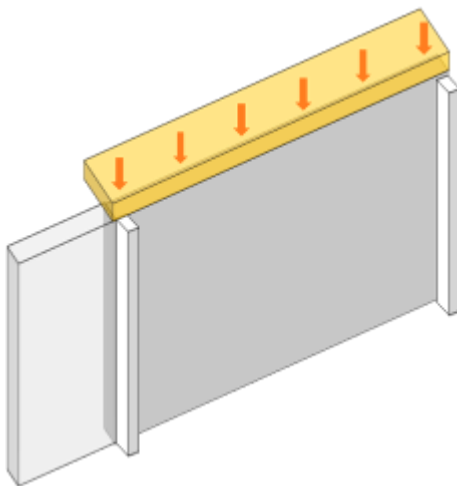

<input checked="" type="checkbox"/>	<input type="checkbox"/>	Is at least one end of the member supported?
<input checked="" type="checkbox"/>	<input type="checkbox"/>	Are both ends of the member supported?
<input checked="" type="checkbox"/>	<input type="checkbox"/>	Is the masonry continuous past at least one support?
<input type="checkbox"/>	<input checked="" type="checkbox"/>	Is the masonry continuous past both supports?
<input checked="" type="checkbox"/>	<input type="checkbox"/>	Is the member supported laterally at the top?
<input checked="" type="checkbox"/>	<input type="checkbox"/>	Is the member loadbearing?
<input checked="" type="checkbox"/>	<input type="checkbox"/>	Does the member support a concrete slab?

**Robustness**

Vertical robustness coefficient AS 3700 Table 4.2  
 $C_v = 48.0$  for reinforced masonry and  $36.0$  for unreinforced masonry,  
 both laterally restrained and supporting a concrete slab

Horizontal robustness coefficient AS 3700 Table 4.2  
 $C_h = 36.0$  for unreinforced masonry with two vertical supports

Height for calculating robustness  
 $H_r = H$   
 $= 2,700$  mm

Length for calculating robustness  
 $L_r = \text{IF}(L_o > 0, L_t, L)$   
 $= 3,700$  mm

Thickness for calculating robustness  
 $t_r = \text{IF}(\text{Construction} = \text{"Single"}, t_u, \text{MAX}(0.6667(t_u + t_{u \text{ minor}}), t_u, t_{u \text{ minor}}))$   
 $= 200$  mm

Maximum permissible height based on robustness criteria  
 $H_{\text{max}} = \text{MAX}(C_v t_r k_t, \text{IF}(L_r / t_r > C_h, t_r (C_v + C_h / (L_r - C_h t_r)), \text{infinite}))$   
 $= \text{MAX}([48 \times 190 \times 1.42], \text{IF}(3,700 / 190 > 36, 190 (48 + 36 / (3,700 - [36 \times 190])), \text{infinite}))$   
 $= \text{infinite}$

**Capacity Reduction Factors**

Capacity reduction factor for compression in unreinforced masonry AS 3700 Table 4.1  
 $\phi_c = 0.45$

Capacity reduction factor for bending & shear in unreinforced masonry AS 3700 Table 4.1  
 $\phi_b = 0.60$

Capacity reduction factor for reinforced masonry AS 3700 Table 4.1  
 $\phi_r = 0.75$

Capacity reduction factor tension and compression in wall ties etc AS 3700 Table 4.1  
 $\phi_t = 0.95$

Capacity reduction factor for other actions in wall accessories AS 3700 Table 4.1  
 $\phi_o = 0.75$

## Masonry Unit Dimensions

## Kerry - New drawing

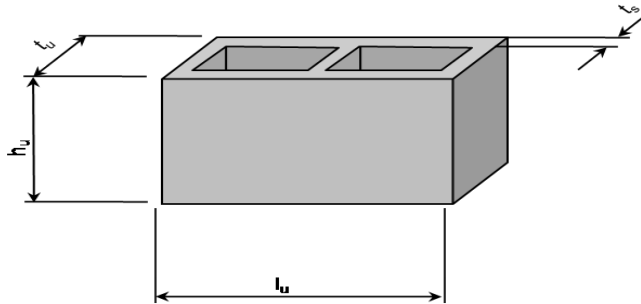

### External Dimensions of Units

Unit length

$$l_u = 600 \text{ mm}$$

Unit height

$$h_u = 200 \text{ mm}$$

Unit thickness

$$t_u = 200 \text{ mm}$$

### Internal Dimensions

Unit = Hollow

Unit face shell width

$$t_{s u} = 35 \text{ mm}$$

A 25 mm face shell bedding surface is used for purposes of calculating lateral modulus of rupture of the units, the bedded area for vertical compressive capacity and the bedded area for flexure of reinforced masonry.

### Masonry Unit Properties

Unit material is "Lightweight"

Basalt content = Under 45%

Material density

$$\rho = 1,040 \text{ kg/m}^3$$

Density classification

Class = "Under 1800"

Density of reinforced concrete masonry

$$\begin{aligned} \rho_r &= 0.5 \rho + (0.5 \times 2,220) \\ &= 1,985 \text{ kg/m}^3 \end{aligned}$$

Unit compressive strength

$$f'_{uc} = 4.0 \text{ MPa for 200 mm hollow Benex units}$$

CSIRO Report DTS767 Page 27 reports 4.92 MPa for 200 mm hollow units (based on two 35 mm wide face shell beds). This manual recommends the specification of 4.0 MPa, giving approximately 20% manufacturing tolerance on strength.

Unit lateral modulus of rupture

$$f'_{ut} = 1.20 \text{ MPa for 200 mm hollow Benex units}$$

CSIRO Report DTS767 Page 79 reports 1.52 MPa for 200 mm hollow units. This is above the default value of 0.80 MPa in AS 3700 Clause 1.5.2.9, which states, "...In the absence of test data, the value of ( $f'_{ut}$ ) is not allowed to exceed 0.8 MPa." AS 3700 is interpreted such that use of the CSIRO test data for lateral modulus of rupture of units does not invoke a classification as "special masonry" with the associated requirements for site testing. This manual recommends the specification of 1.20 MPa, giving approximately 20% manufacturing tolerance on lateral modulus of rupture.

## Masonry Properties

Masonry flexural strength AS 3700 3.3.3  
 $f'_{mt} = 0.20 \text{ MPa}$

CSIRO Report DTS767 Page 78 reports 0.27 MPa for 200 mm hollow units (based on two 35 mm wide face shell beds). Both are above the default value of 0.20 MPa for normal masonry in AS 3700 Clause 3.3.3. By adopting 0.20 MPa, the requirement for site testing associated with "special masonry" is avoided.

Masonry shear strength AS 3700 3.3.4  
 $f'_{vm} = 0.35$  or "Input"  
 $= 0.35 \text{ MPa}$

Masonry shear factor AS 3700 3.3.5, Table 3.3  
 $k_v = 0.30$

Proprietary thin-bed adhesive

Adhesive joint thickness  
 $t_j = \text{Up to 2 mm maximum}$

Minimum overlap of masonry units in successive courses  
 $s_p = (l_u + t_j)/2 - t_j$   
 $= (600 + 2)/2 - 2$   
 $= 299 \text{ mm}$

Bedding surface width  
 $t_s = 25 \text{ mm}$

Based on the CSIRO report, two 25 mm face shell bedding surfaces are used for purposes of calculating vertical bending strength, horizontal bending strength, and the associated wall flexure capacities.

Section modulus of the perpendicular joints (per metre length)  
 $Z_p = 1,000 t_u^2 / 6 \cdot [6 (t_s / t_u) - 12 (t_s / t_u)^2 + 8 (t_s / t_u)^3]$   
 $= 1,000 \times 200^2 / 6 \cdot [6 (25 / 200) - 12 (25 / 200)^2 + 8 (25 / 200)^3]$   
 $= 3,854,000 \text{ mm}^3/\text{m}$

The value recommended for design is 3,854,000 mm<sup>3</sup>/m for 200 mm hollow units (based on two 25 mm wide face shell beds).

Notes:

- Although each face shell of the 200 mm unit is 35 mm wide, the CSIRO have recommended basing the calculations on two 25 mm strips of thin-bed adhesive for the perpendicular joints.
- The recommended values are "per metre" run of joint, and do not take into account the fact that the units and joints alternate. This fact is considered in the calculation of the horizontal moment capacity, using an approach consistent with AS 3700. CSIRO Report DTS767 adopts an alternative approach (described in Point 3 below), but the end result is identical.

3. CSIRO Report DTS767 Page 54 reports 1,927,083 mm<sup>3</sup>/m for 200 mm hollow units (based on two 25 mm wide face shell perpendicular joints). This is half the value recommended in this design example, since it takes into account the fact that perpendicular joints and units alternate in stretcher bond. This fact is considered elsewhere in the recommended design.

Section modulus of the units

$$\begin{aligned} Z_u &= 1,000 t_u^2 / 6 \cdot [6 (t_{s,u} / t_u) - 12 (t_{s,u} / t_u)^2 + 8 (t_{s,u} / t_u)^3] \\ &= 1,000 \times 200^2 / 6 \cdot [6 (35 / 200) - 12 (35 / 200)^2 + 8 (35 / 200)^3] \\ &= 4,836,000 \text{ mm}^3/\text{m} \end{aligned}$$

The value recommended for design is 4,836,000 mm<sup>3</sup>/m for 200 mm hollow units (based on two 35 mm wide face shell).

Notes:

1. The recommended value is “per metre” run of unit, and does not take into account the fact that the units and joints alternate. This fact is considered in the calculation of the horizontal moment capacity, using an approach consistent with AS 3700. CSIRO Report DTS767 adopts an alternative approach (described in Point 2 below), but the end result is identical.
2. CSIRO Report DTS767 Page 54 reports 2,417,916 mm<sup>3</sup>/m for 200 mm hollow units (based on two 35 mm wide face shells). This value is half the value recommended in this design example, since it takes into account the fact that perpendicular joints and units alternate in stretcher bond. This fact is considered elsewhere in the recommended design.

Section modulus of the bedding surface (per metre length)

$$\begin{aligned} Z_d &= 1000 t_u^2 / 6 \cdot [6 (t_s / t_u) - 12 (t_s / t_u)^2 + 8 (t_s / t_u)^3] \\ &= 1000 \times 200^2 / 6 \cdot [6 (25 / 200) - 12 (25 / 200)^2 + 8 (25 / 200)^3] \\ &= 3,854,167 \text{ mm}^3/\text{m} \end{aligned}$$

Net area of section

$$\begin{aligned} A_b &= 2 t_{s,u} \cdot 1,000 \\ &= 2 \times 35 \times 1,000 \\ &= 70,000 \text{ mm}^2/\text{m} \end{aligned}$$

Area that cannot be filled by either bed joint or concrete grout

$$A_b = 0 \text{ mm}^2/\text{m}$$

Proportion of the cores spaces are grouted = 25 %

Design cross sectional area of grout

$$\begin{aligned} A_c &= (1,000 t_u - A_b - A_b) \cdot \text{Grout} \\ &= ([1,000 \times 200] - 70,000 - 0) \times 25 / 100 \\ &= 32,500 \text{ mm}^2/\text{m} \end{aligned}$$

## Masonry Properties

Characteristic masonry strength

$$\begin{aligned}
 f'_m &= 0.74 f'_{uc} \\
 &= 0.74 \times 4.0 \text{ MPa} \\
 &= 3.0 \text{ MPa}
 \end{aligned}$$

CSIRO Report DTS767 Page 78 reports 0.74  $f'_{uc}$  for 200 mm hollow units (for use with two 35 mm wide face shell beds).

Concrete grout specification AS 3700 Clause 5.6, 10.7

*Concrete grout shall comply with AS 3700 and have:*

- a minimum portland cement content of 300 kg/cubic metre;
- a maximum aggregate size of 10 mm;
- sufficient slump to completely fill the cores
- a pumpable consistency; and
- a minimum compressive cylinder strength of 20 MPa.

Grout strength

$$\begin{aligned}
 f'_c &= 20 \text{ MPa} \\
 &> 12 \text{ MPa} \quad \text{OK} \quad \text{AS 3700 Clause 10.7.3}
 \end{aligned}$$

Design characteristic compressive strength of grout

$$\begin{aligned}
 f'_{cg} &= \min (f'_{cg \text{ nom}}, 1.3 f'_{uc}) \quad \text{AS 3700 Clause 3.5} \\
 &= \min (15.0, 1.3 \times 4.0) \\
 &= 5.2 \text{ MPa}
 \end{aligned}$$

## Resistance to Compression

Density factor

$$k_c = 1.20$$

For hollow units with a density greater than 2,000 kg/m<sup>3</sup> 1.4  
 For other units 1.2

Basic compressive strength capacity

$$\begin{aligned}
 F_o &= \phi_c (f'_m A_b + k_c (f'_{cg} / 1.3)^{0.5} A_c) / 1000 \\
 &= 0.45 ([3.0 \times 70,000] + [1.20 \times (5.2 / 1.3)^{0.5} \times 32,500]) / 1,000 \\
 &= 128. \text{ kN/m}
 \end{aligned}$$

Vertical slenderness coefficient

$$a_v = 0.75$$

No top support	2.5
Partial top support, laterally restrained, and partially rotationally restrained at bottom	1.5
Laterally restrained at top and bottom, no rotational restraint	1.0
Laterally restrained at top and bottom, partially rotationally restrained at one of them	0.85
Laterally restrained, partially rotationally restrained at top and bottom	0.75

Horizontal slenderness coefficient

$$\begin{aligned}
 a_h &= 1.00 \\
 &\text{Laterally supported at both vertical ends } 1.0 \\
 &\text{Laterally supported at one vertical end } 2.5
 \end{aligned}$$

Slenderness for refined calculation

$$\begin{aligned}
 S_r &= \text{MIN} (a_v H / (k_t t_w), 0.7 (a_v H a_h \text{IF} (L_o > 0, L_t, L))^{0.5} / t_w) \\
 &= \text{MIN} (0.75 \times 3,800 / (1.53 \times 200), 0.7 (0.75 \times 3,800 \times 1.00 \times 6,600)^{0.5} / 200) \\
 &= \text{MIN} (9.33, 15.18) \\
 &= 9.33
 \end{aligned}$$

Eccentricity at the top  
 $e_1 = 33.3 \text{ mm}$

Eccentricity must be determined by the engineer.

Eccentricity at the base  
 $e_2 = 33.3 \text{ mm}$

Eccentricity must be determined by the engineer.

Eccentricity ratio at the top of the wall  
 $e_1/t_w = e_1 / t_w$   
 $= 33.3 / 200$   
 $= 0.167$

Reduction factor (for eccentricity and slenderness)

$$k_{e,s} = \text{IF}(e_1/t_w > 0.499, 0, \text{MAX}(0, \text{MIN}(1, \text{IF}(e_1/t_w > 0.05, 0.5(1+e_2/e_1)*((1-2.083e_1/t_w)-(0.025-0.037e_1/t_w)(1.33S_r-8))+0.5(1-0.6 e_1/t_w)(1-e_2/e_1)(1.18-0.03S_r), 1.18 - 0.03 S_r ))))$$

$$= \text{IF}(0.167 > 0.499, 0, \text{MAX}(0, \text{MIN}(1, \text{IF}(0.167 > 0.05, 0.5*(1 + 33.3 / 33.3) * ((1 - [2.083 * 0.167]) - (0.025 - [0.037 * 0.167]) ([1.33 * 9.33] - 8) + 0.5 (1 - [0.6 * 0.167]) * (1 - 33.3 / 33.3) (1.18 - [0.03 * 9.33]) , 1.18 - [0.03 * 9.33] ))))$$

$$= 0.570$$

Reduction factor (for eccentricity and slenderness)

$$k_{\text{crush}} = \text{For "Solid/Cored" units, } 1 - 2 e_1/t_w ,$$

$$\text{For "Hollow" units, } \text{MIN}( (1 - t_s / t_w) / (1 - t_s / t_w + 2 e_1/t_w) , (1 - 2 e_1/t_w) / (2 t_s / t_w) )$$

$$= \text{MIN}( (1 - 35 / 200) / (1 - 35 / 200 + [2 * 0.167]) , (1 - [2 * 0.167]) / (2 * 35 / 200) )$$

$$= 0.724$$

Reduction factor (for eccentricity, slenderness and crushing)

$$k = \text{MIN}(k_{e,s}, k_{\text{crush}})$$

$$= \text{MIN}(0.570, 0.724)$$

$$= 0.570$$

Design compressive strength

$$k F_o = k F_o$$

$$= 0.570 \times 128.$$

$$= 73.0 \text{ kN/m}$$

Design compressive strength of the whole length of member

$$k F_o L = k F_o \cdot L / 1,000$$

$$= 73.0 \times 6,600 / 1,000$$

$$= 481. \text{ kN}$$

## Resistance to Concentrated Loads

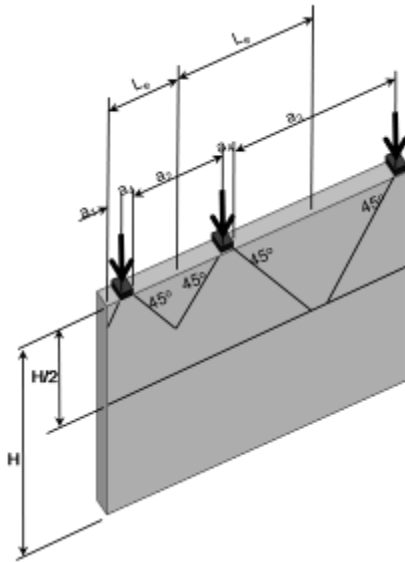

Distance from the end of the wall to the point load (if near the end)

$$a_1 = 300 \text{ mm}$$

Distance to the closest point load on the right

$$a_2 = 600 \text{ mm}$$

Distance to next point load on the right

$$a_3 = 600 \text{ mm}$$

Length over which the point load is spread (at the point of contact)

$$a_4 = 100 \text{ mm}$$

Effective dispersion length of the concentrated load close to the end of the wall

$$\begin{aligned} L_{e e} &= \text{MIN} (L, \text{MIN}(a_{1 e}, H/2) + a_{4 e} + \text{MIN}(a_{2 e} / 2, H/2)) \\ &= \text{MIN} (6,600, \text{MIN}(300, 3,800 / 2) + 100 + \text{MIN}(600 / 2, 3,800 / 2)) \\ &= 700 \text{ mm} \end{aligned}$$

Effective dispersion length of concentrated load away from the end of the wall

$$\begin{aligned} L_{e i} &= \text{MIN} (a_{2 i} / 2, H/2) + a_{4 i} + \text{MIN} (a_{3 i} / 2, H/2) \\ &= \text{MIN} (600 / 2, 2,700 / 2) + 100 + \text{MIN} (600 / 2, 2,700 / 2) \\ &= 700 \text{ mm} \end{aligned}$$

Effective dispersion area of concentrated load at mid-height

$$\begin{aligned} A_{dc} &= 2 t_{su} L_e \\ &= 2 \times 35 \times 700 \\ &= 49,000 \text{ mm}^2 \end{aligned}$$

Bearing area

$$\begin{aligned} A_{ds} &= 2 t_{su} a_{4 e} \\ &= 2 \times 35 \times 100 \\ &= 7,000 \text{ mm}^2 \end{aligned}$$

Concentrated bearing factor

$$\begin{aligned} k_{b e} &= \text{MAX} (1, \text{MIN} (0.55 (1 + 0.5 a_{1 e} / L) / ((A_{ds e} / A_{dc e})^{0.33}), 1.5 + a_{1 e} / L), 1) \\ &= \text{Max} (1, \text{MIN} (0.55 (1 + [0.5 \times 300 / 6,600]) / ((7,000 / 49,000)^{0.33}), 1.5 + 300 / 6,600), 1) \\ &= 1.0 \end{aligned}$$

Compressive strength capacity immediately under concentrated load (modified for concentration)

$$\begin{aligned} k_b F_{o a 4 e} &= k_b \cdot F_o \cdot a_{4 e} / 1,000 \\ &= 1.0 \times 128 \times 100 / 1,000 \end{aligned}$$

$$= 12.8 \text{ kN}$$

Dispersed compressive load at mid-height of the wall

$$\begin{aligned} W_{\text{mid e}} &= P_{\text{max e}} / L_{\text{e e}} \times 1,000 \\ &= 19.5 / 700 \times 1,000 \\ &= 27.9 \text{ kN/m} \end{aligned}$$

Concentrated point loads

$$P_{\text{conc}} = 19.5 \text{ kN}$$

Number of point loads

$$N_{\text{cl}} = 11$$

Total of concentrated point loads

$$\begin{aligned} P_{\text{tot conc}} &= P_{\text{conc}} N_{\text{cl}} \\ &= 19.5 \times 11 \\ &= 215 \text{ kN} \end{aligned}$$

### Resistance to Bending (Unreinforced Masonry)

CSIRO Report DTS767 Page 78 provides a design method, similar to that in AS 3700 Clause 7.4.4.3, that is suitable for designing unreinforced Benex Masonry walls, without openings, for out-of-plane bending.

If it is intended that the wall should include openings, it is necessary to support the edges of the opening by external supports, or by a reinforced cores. Refer to the later section on Reinforced Masonry.

Vertical compressive unfactored stress due to external load (unfactored vertical permanent line load)

$$\begin{aligned} f_{\text{dt}} &= 1,000 W_{\text{p v}} / A_{\text{b}} \\ &= 1,000 \times 20.0 / 70,000 \\ &= 0.29 \text{ MPa} \end{aligned}$$

The calculated vertical bending capacity of the wall is contingent on the vertical compressive stress induced by any external loading. In this worked example, an unfactored vertical compressive load of 20 kN/m has been used.

Vertical compressive unfactored stress at mid height of wall due to self weight

$$\begin{aligned} f_{\text{d sm}} &= \rho H \square t_{\text{e}} 9.81 / (2 A_{\text{b}} 10^6) \\ &= 1,042 \times 3,800 \times 110 \times 9.81 / (2 \times 70,000 \times 10^6) \\ &= 0.03 \text{ MPa} \end{aligned}$$

Vertical compressive unfactored stress at base of wall due to self weight

$$\begin{aligned} f_{\text{d sb}} &= \rho H \square t_{\text{e}} 9.81 / (A_{\text{b}} 10^6) \\ &= 1,042 \times 3,800 \times 110 \times 9.81 / (70,000 \times 10^6) \\ &= 0.06 \text{ MPa} \end{aligned}$$

Vertical compressive unfactored stress at mid height of wall

$$\begin{aligned} f_{\text{d m}} &= f_{\text{dt}} + f_{\text{d sm}} \\ &= 0.29 + 0.03 \\ &= 0.32 \text{ MPa} \end{aligned}$$

Vertical compressive unfactored stress at base of wall

$$\begin{aligned} f_{\text{d b}} &= f_{\text{dt}} + f_{\text{d sb}} \\ &= 0.29 + 0.06 \\ &= 0.35 \text{ MPa} \end{aligned}$$

Bending moment capacity factor

$$k_{\text{mt}} = 1.0$$

For "AAC"	1.3
For other materials	1.0

Perpend spacing factor

$$\begin{aligned}
 k_p &= \text{MIN}(s_p/t_u, s_p/h_u, 1.0) \\
 &= \text{MIN}(300/200, 200/200, 1.0) \\
 &= 1.0
 \end{aligned}$$

Vertical bending moment capacity

$$\begin{aligned}
 M_{cv} &= \text{MIN}(\phi_b k_{mt} f_{mt} Z_d + f_{dm} Z_d, 3 \phi_b k_{mt} f_{mt} Z_d) / 10^6 \\
 &= \text{MIN}([0.60 \times 1.0 \times 0.20 \times 3,854,167] + [0.35 \times 3,854,167], \\
 &\quad [3 \times 0.60 \times 1.0 \times 0.20 \times 3,854,167]) / 10^6 \\
 &= \text{MIN}(1.68, 1.39) \\
 &= 1.39 \text{ kN.m/m}
 \end{aligned}$$

Horizontal bending moment capacity

$$\begin{aligned}
 M_{ch} &= \phi_b (0.3 f_{ut} Z_u/2 + 0.7 f_{mt} Z_p/2) / 10^6, \\
 &= 0.6 ([0.3 \times 1.50 \times 4,836,000 / 2] + [0.7 \times 0.2 \times 3,854,000 / 2]) / 10^6 \\
 &= 0.6 (1.09 + 0.27) \\
 &= 0.815 \text{ kN/m}
 \end{aligned}$$

Lateral load capacity for two-way action (limited by masonry bending)

$$\begin{aligned}
 \phi W_{d2b} &= 15 (b_v M_{cv} / H^2 + b_h M_{ch} / L^2) H / L \cdot 1,000,000 \\
 &= 15 ([1.0 \times 1.39 / 3,800^2] + [1.25 \times 0.815 / 6,600^2]) \times 3,800 / 6,600 \times 1,000,000 \\
 &= 1.032 \text{ kPa}
 \end{aligned}$$

Lateral load capacity for one-way action (limited by masonry bending)

$$\begin{aligned}
 \phi W_{d1b} &= 8 M_{cv} / H^2 \times 10^6 \\
 &= 8 \times 1.39 / 3,800^2 \times 10^6 \\
 &= 0.77 \text{ kPa}
 \end{aligned}$$

### Resistance to In-Plane Shear

In plane shear capacity

$$\begin{aligned}
 \phi V &= A_b (0.3 \phi + 0.5 f_d) / 10^3 \\
 &= 70,000 ([0.3 \times 0.60] + [0.5 \times 0.35]) / 10^3 \\
 &= 24.9 \text{ kN/m}
 \end{aligned}$$

CSIRO Report DTS767 Page 79 provides a design method for determining the shear capacity of unreinforced Benex Masonry walls. For 200 mm hollow units, where  $A_b$  is the bedded area based on face shell bedding: In-plane shear capacity,  $\phi V = A_b (0.3 \phi + 0.5 f_d)$

## Resistance to Bending (Reinforced Masonry)

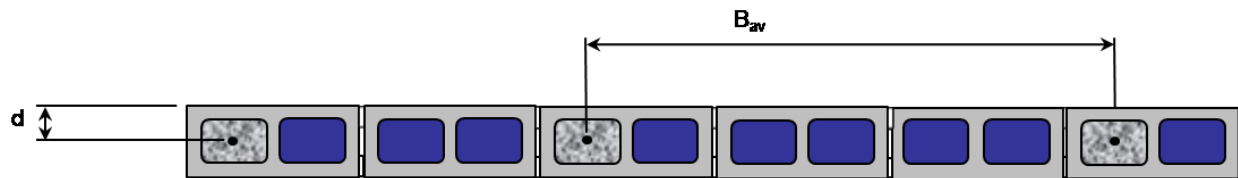

CSIRO Report DTS76 does not provide a design method for reinforced Benex Masonry. However, it does provide the basic properties of Benex Masonry for use in AS 3700 Section 8. Therefore, it is both reasonable and conservative to use AS 3700 Section 8 to design reinforced Benex Masonry.

Clear span of member  
 $L_c = 3,800 \text{ mm}$

Total length of wall  
 $B_{tot} = 6,600 \text{ mm}$

Number of reinforced members within the wall  
 $N = 5$

Spacing of reinforced members (i.e. reinforced cores) along the wall  
 $B_{space} = 600 \text{ mm}, 1,200 \text{ mm} \text{ or } 2,400 \text{ mm}.$

Design width of masonry supported by reinforced members  
 $B = \max (B_o, L/N)$   
 $= \max (1,800, 6,600/5)$   
 $= 1,800 \text{ mm}$

Width of masonry contributing to the compression face of each reinforced member  
 $b = \min ([4 \cdot t_u + B_i], B)$   
 $= \min ([4 \times 200] + 0, 1,217)$   
 $= 800 \text{ mm}$

Average shear width of each masonry member  
 $b_w = 300 \text{ mm}$

Second moment of area of reinforced section (based on gross section)  
 $I = B D^3 / 12$   
 $= 1,800 \times 200^3 / 12$   
 $= 1.20 \times 10^9 \text{ mm}^4$

Reinforcement strength grade  
 $f_{s y m} = 500 \text{ MPa}$

Main reinforcement shear strength (dowel action)  
 $f_{s v} = 17.5 \text{ MPa}$

Reinforcement nominal diameter  
 $R_{m \text{ dia}} = 16 \text{ mm} \text{ or "Input"}$   
 $= 16 \text{ mm}$

Number of reinforcing bars in tension in each reinforced member  
 $N_{t m} = 1$

Total depth of section  
 $D_m = 200 \text{ mm}$

Depth to the centroid of the tensile steel from the compression face

$$d = 100 - 16$$

$$= 84 \text{ mm}$$

Absolute deflection limit AS 3700 J4, J5

$$\Delta_{\max} = 20 \text{ mm}$$

Span / deflection limit AS 3700 J4, J5

$$L_c / \Delta_{\min} = 150$$

Restraint at supports = Simply Supported

Shear coefficient

$$K_{\text{shear}} = 2$$

For "Simply Supported", use 2.00  
For "Partially Restrained", use 1.60  
For "Fully Restrained", use 2.00

Bending coefficient

$$K_{\text{bend}} = 8$$

For "Simply Supported", use 8  
For "Partially Restrained", use 8  
For "Fully Restrained", use 12

Deflection coefficient

$$K_{\text{def}} = 0.0130$$

For "Simply Supported", use 0.013  
For "Partially Restrained", use 0.0054  
For "Fully Restrained", use 0.0026

Area of all main tensile reinforcement bars in the member

$$A_{\text{st}} = N_{\text{tm}} \cdot A_{\text{st}1}$$

$$= 1 \times 200$$

$$= 200 \text{ mm}^2 \text{ for a single N16 vertical bar}$$

Design area of main tensile reinforcement in the member

$$A_{\text{sd}} = \min [ 0.29 (1.3 f'_m) b d / f_{\text{sy}}, A_{\text{st}} ]$$

$$= \min [ (0.29 \times 1.3 \times 3.0 \times 800 \times 84 / 500), 200 ]$$

$$= \min [ 150, 200 ]$$

$$= 150 \text{ mm}^2$$

Elastic modulus of reinforced masonry under short-term loading

$$E_{\text{rs}} = 1,000 f'_c$$

$$= 1,000 \times 20$$

$$= 20,000 \text{ MPa}$$

Shear capacity

$$\phi_r V = \phi_r (f'_{\text{vm}} b_w d + f_{\text{vs}} A_{\text{st}} + f_{\text{sy}f} A_{\text{sv}} d / s)$$

$$= 0.75 [(0.35 \times 300 \times 84) + (17.5 \times 200) + (500 \times 0 \times 100 / 0)] / 10^3$$

$$= 0.75 (8.82 + 3.50 + 0.0)$$

$$= 9.24 \text{ kN}$$

Bending moment capacity

$$\phi_r M = \phi_r f_{\text{sy}} A_{\text{sd}} d [1 - 0.6 f_{\text{sy}} A_{\text{sd}} d / (1.3 f'_m b d)]$$

$$= 0.75 \times 500 \times 150 \times 84 [1 - (0.6 \times 500 \times 150) / (1.3 \times 3.0 \times 800 \times 84)] / 10^6$$

$$= 3.90 \text{ kN.m}$$

Limiting deflection

$$\Delta_a = \text{MIN} (\phi_{\text{max}}, L_c / ([L_c / \phi_{\text{min}}]))$$

$$= \min (20, 3,800 / 150)$$

$$= 20.0 \text{ mm}$$

Load capacity (limited by shear)

$$\begin{aligned}\phi \square w_{vr} &= K_{\text{shear}} \phi_r V / (L_c k_u) \cdot 10^3 \\ &= 2 \times 9.24 / (3,800 \times 1.0) \times 10^3 \\ &= 4.86 \text{ kN/member}\end{aligned}$$

Load capacity (limited by bending moment)

$$\begin{aligned}\phi \square w_{br} &= K_{\text{bend}} \phi_r M / (L_c^2 k_{mu}) \cdot 10^6 \\ &= 8 \times 3.90 / (3,800^2 \times 1.0) \times 10^6 \\ &= 2.16 \text{ kN/ member}\end{aligned}$$

Load capacity (limited by deflection)

$$\begin{aligned}\phi \square w_{\Delta r} &= \Delta_a E I / (K_{\text{def}} L_c^4 k_u) \\ &= 20.0 \times 20,000 \times 10^3 \times 1.20 \times 10^9 / (0.0130 \times 3,800^4 \times 1.0) \\ &= 177. \text{ kN/ member}\end{aligned}$$

Load capacity (limited by shear, bending moment or deflection)

$$\begin{aligned}\phi \square w_r &= \min (w_{vr}, w_{br}, w_{\Delta r}) \\ &= \min (4.86, 2.16, 177.) \\ &= 2.16 \text{ kN/ member}\end{aligned}$$

Pressure capacity (limited by shear, bending moment or deflection)

$$\begin{aligned}\phi \square w_r &= \phi \square w_r / B \cdot 10^3 \\ &= 2.16 / 2,400 \times 10^3 \\ &= 0.90 \text{ kPa}\end{aligned}$$

## Connections

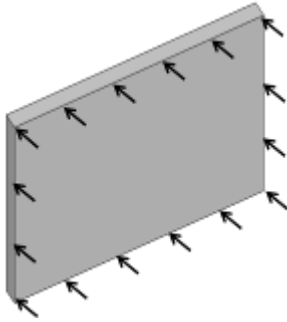

The connections must have sufficient combined capacity to transmit the horizontal in-plane and out-of-plane loads from the wall to the supports. They must also be such that the assumed action of the wall panel can be achieved. For example, if two-way action has been assumed, the connections at the top, bottom and each side must be consistent with the assumed support configuration.

The following calculations provide a guide to the determination of the connection capacities. For top, base and sides, the connection capacities may be provided by a combination of:

- Masonry Bond and Friction (friction will not be applicable for side supports)
- Steel Starter Bars, set in concrete slabs or columns
- Other Connectors, such as proprietary ties.

### Connection at Top

#### Masonry Bond and Friction

Does the masonry transmit load to the support via bond and/or friction?

Top Masonry = Yes

Masonry flexural strength

$$f'_{mtt} = 0 \text{ MPa}$$

Masonry shear strength

$$f'_{mst} = 0.35 \text{ MPa}$$

Masonry shear factor for friction

$$k_{vt} = 0.3$$

If "Top Masonry" is "Yes", a value of 0.3 would be common. Otherwise 0 should be used.  
Refer also to AS 3700 Table 3.5.

#### Steel Starter Bars

Does the masonry transmit load to the support via steel starter bars?

Top Starters = No

Steel starter bar diameter

$$R_{dia\ cont} = 0 \text{ mm}$$

Steel starter bar spacing

$$S_{cont} = 0 \text{ mm}$$

Steel starter bar strength

$$f'_{sy\ cont} = 0 \text{ MPa}$$

#### Other Connectors

Does the masonry transmit load to the support via other connectors?

Top Connectors = No

Specified connector unfactored tensile capacity

$$F_{tct} = 0 \text{ kN/m}$$

Specified connector unfactored shear capacity

$$V_{sc\ t} = 0 \text{ kN/m}$$

#### Restraint

Lateral restraint provided by this connection

Lat<sub>t</sub> = Full, indicating that the member supported laterally at the top.

Rotational restraint provided by this connection

Rot<sub>t</sub> = Partial, indicating that the member supports a concrete slab.

#### **Connection at Base**

##### Masonry Bond and Friction

Does the masonry transmit load to the support via bond and/or friction?

Base Masonry = Yes

Masonry flexural strength

$$f'_{mt\ b} = 0 \text{ MPa}$$

Masonry shear strength

$$f'_{ms\ b} = 0 \text{ MPa}$$

Masonry shear factor for friction

$$k_{v\ b} = 0.3$$

If "Base Masonry" is "Yes", a value of 0.3 would be common. Otherwise 0 should be used.  
Refer also to AS 3700 Table 3.5.

##### Steel Starter Bars

Does the masonry transmit load to the support via steel starter bars?

Base Starters = Yes

Steel starter bar diameter

$$R_{dia\ con\ b} = 12 \text{ mm}$$

Steel starter bar spacing

$$S_{con\ b} = 1,800 \text{ mm}$$

Steel starter bar strength

$$f'_{sy\ con\ b} = 500 \text{ MPa}$$

##### Other Connectors

Does the masonry transmit load to the support via other connectors?

Top Connectors = No

Specified connector unfactored tensile capacity

$$F_{tc\ b} = 0 \text{ kN/m}$$

Specified connector unfactored shear capacity

$$V_{sc\ b} = 1.0 \text{ kN/m}$$

#### Restraint

Lateral restraint provided by this connection

Lat<sub>b</sub> = Full

Rotational restraint provided by this connection

Rot<sub>b</sub> = Partial

**Connection at Left End**Masonry Bond and Friction

Does the masonry transmit load to the support via bond and/or friction?

Left Masonry = Yes

Masonry flexural strength

$$f'_{mtl} = 0.20 \text{ MPa}$$

Masonry shear strength

$$f'_{msl} = 0.35 \text{ MPa}$$

Masonry shear factor for friction

$$k_{vl} = 0.0$$

For a vertical connection, the masonry shear factor for friction will always be 0.

Steel Starter Bars

Does the masonry transmit load to the support via steel starter bars?

Left Starters = No

Steel starter bar diameter

$$R_{dia\ con\ l} = 0 \text{ mm}$$

Steel starter bar spacing

$$S_{con\ l} = 0 \text{ mm}$$

Steel starter bar strength

$$f'_{sy\ con\ l} = 0 \text{ MPa}$$

Other Connectors

Does the masonry transmit load to the support via other connectors?

Left Connectors = No

Specified connector unfactored tensile capacity

$$F_{tcl} = 0 \text{ kN/m}$$

Specified connector unfactored shear capacity

$$V_{sc\ l} = 0 \text{ kN/m}$$

Restraint

Lateral restraint provided by this connection

Lat<sub>l</sub> = Full, indicating the member is supported

Rotational restraint provided by this connection

Rot<sub>l</sub> = Partial, indicating the masonry is continuous past the support

**Connection at Right End**Masonry Bond and Friction

Does the masonry transmit load to the support via bond and/or friction?

Right Masonry = No

Masonry flexural strength

$$f'_{mtr} = 0 \text{ MPa}$$

Masonry shear strength

$$f'_{msr} = 0 \text{ MPa}$$

Masonry shear factor for friction

$$k_{vr} = 0$$

For a vertical connection, the masonry shear factor for friction will always be 0.

Steel Starter Bars

Does the masonry transmit load to the support via steel starter bars?

Right Starters = No

Steel starter bar diameter

$$R_{\text{dia con r}} = 0 \text{ mm}$$

Steel starter bar spacing

$$S_{\text{con t}} = 0 \text{ mm}$$

Steel starter bar strength

$$f'_{\text{sy con r}} = 0 \text{ MPa}$$

Other Connectors

Does the masonry transmit load to the support via other connectors?

Right Connectors = No

Specified connector unfactored tensile capacity

$$F_{\text{tc r}} = 0 \text{ kN/m}$$

Specified connector unfactored shear capacity

$$V_{\text{sc r}} = 3.0 \text{ kN/m}$$

Restraint

Lateral restraint provided by this connection

Lat<sub>r</sub> = Full, indicating the member is supported

Rotational restraint provided by this connection

Rot<sub>r</sub> = Nil, indicating the masonry is not continuous past the support

**Out-of-Plane Shear Capacity of Connections**

Shear capacity of support at top

$$\begin{aligned} \phi V_{\text{dt}} &= (\phi_b f'_{\text{ms t}} A_b / 1000 + k_{\text{vt}} f_{\text{dt}} A_b / 1000) \\ &\quad + (\square \phi_r 17.5 \times 3.1416 R_{\text{dia con t}}^2 / 4 \text{ IF}(S_{\text{con t}} = 0,0,1000 / S_{\text{con t}}) / 1000) \\ &\quad + (\square \phi_o V_{\text{sc t}}) \\ &= (0.60 \times 0 \times 60,000 / 1000 + 0.30 \times 0.352 \times 60,000 / 1000) \\ &\quad + (0.75 \times 17.5 \times 3.1416 \times 0^2 / 4 \text{ IF}(0 = 0,0,1000/0)/1000) \\ &\quad + (0.75 \times 0) \\ &= 6.3 \text{ kN.m} \end{aligned}$$

Shear capacity of support at base

$$\begin{aligned} \phi V_{\text{db}} &= (\phi_b f'_{\text{ms b}} A_b / 1000 + k_{\text{vb}} f_{\text{db}} A_b / 1000) \\ &\quad + (\square \phi_r 17.5 \times 3.1416 R_{\text{dia con b}}^2 / (4 \times S_{\text{con b}})) \\ &\quad + (\square \phi_o V_{\text{sc b}}) \\ &= (0.60 \times 0.35 \times 70,000 / 1000 + 0.30 \times 0.39 \times 70,000 / 1000) \\ &\quad + (0.75 \times 17.5 \times 3.1416 \times 12^2 / (4 \times 1,800)) \\ &\quad + (0.75 \times 0) \\ &= (14.7 + 8.2 + 0.8 + 0) \\ &= 23.8 \text{ kN.m} \end{aligned}$$

Shear capacity of support at left end

$$\begin{aligned} \phi V_{\text{dl}} &= (\phi_b f'_{\text{ms l}} A_b / 1000) \\ &\quad + (\square \phi_r 17.5 \times 3.1416 R_{\text{dia con l}}^2 / (4 \times S_{\text{con l}})) \\ &\quad + (\square \phi_o V_{\text{sc l}}) \\ &= (0.60 \times 0.35 \times 70,000 / 1000) \\ &\quad + (0.75 \times 17.5 \times 3.1416 \times 0^2 / (4 \times \text{infinite})) \\ &\quad + (0.75 \times 0) \\ &= 14.7 \text{ kN.m} \end{aligned}$$

Shear capacity of support at right end

$$\begin{aligned}\phi V_{d,r} &= (\phi_b f'_{ms,r} A_b / 1000) \\ &\quad + (\square \phi_r 17.5 \times 3.1416 R_{dia,con,r}^2 / (4 \times S_{con,r})) \\ &\quad + (\square \phi_o V_{sc,r}) \\ &= (0.60 \times 0 \times 70,000 / 1000) \\ &\quad + (0.75 \times 17.5 \times 3.1416 \times 0^2 / (4 \times infinite)) \\ &\quad + (0.75 \times 3.0) \\ &= 2.3 \text{ kN.m}\end{aligned}$$

Two-way action

Length supported by the top connection

$$L_{con,2,t} = 6,600 \text{ mm}$$

Length supported by the base connection

$$L_{con,2,b} = 6,600 \text{ mm}$$

Length supported by the left connection

$$L_{con,2,l} = 3,800 \text{ mm}$$

Length supported by the right connection

$$L_{con,2,r} = 3,800 \text{ mm}$$

Total length supported by the connections

$$\begin{aligned}L_{con,2} &= L_{con,2,t} + L_{con,2,b} + L_{con,2,l} + L_{con,2,r} \\ &= 6,600 + 6,600 + 3,800 + 3,800 \\ &= 20,800 \text{ mm}\end{aligned}$$

Area supported by top connection

$$\begin{aligned}A_{con,2,t} &= H. L. L_{con,2,t} / L_{con,2} / 10^6 \\ &= 3,800 \times 6,600 \times 6,600 / 20,800 / 10^6 \\ &= 8.0 \text{ m}^2\end{aligned}$$

Area supported by base connection

$$\begin{aligned}A_{con,2,b} &= H. L. L_{con,2,b} / L_{con,2} \\ &= 3,800 \times 6,600 \times 6,600 / 20,800 / 10^6 \\ &= 8.0 \text{ m}^2\end{aligned}$$

Area supported by left connection

$$\begin{aligned}A_{con,2,l} &= H. L. L_{con,2,l} / L_{con,2} \\ &= 3,800 \times 6,600 \times 3,800 / 20,800 / 10^6 \\ &= 4.6 \text{ m}^2\end{aligned}$$

Area supported by right connection

$$\begin{aligned}A_{con,2,r} &= H. L. L_{con,2,r} / L_{con,2} \\ &= 3,800 \times 6,600 \times 3,800 / 20,800 / 10^6 \\ &= 4.6 \text{ m}^2\end{aligned}$$

Total area supported connections

$$\begin{aligned}A_{con,2} &= A_{con,2,t} + A_{con,2,b} + A_{con,2,l} + A_{con,2,r} \\ &= 8.0 + 8.0 + 4.6 + 4.6 \\ &= 25.4 \text{ m}^2\end{aligned}$$

Capacity of top connection

$$\begin{aligned}\phi V_{d,2,t} &= \phi V_{d,t} A_{con,2,t} \\ &= 6.3 \times 8.0 \\ &= 50. \text{ kN}\end{aligned}$$

Capacity of base connection

$$\phi V_{d,2,b} = \phi V_{d,b} A_{con,2,b}$$

$$= 23.8 \times 8.0$$

$$= 190. \text{ kN}$$

Capacity of left connection

$$\phi V_{d2l} = \phi V_{dl} A_{con2l}$$

$$= 14.7 \times 4.6$$

$$= 67. \text{ kN}$$

Capacity of right connection

$$\phi V_{d2r} = \phi V_{dr} A_{con2r}$$

$$= 2.3 \times 4.6$$

$$= 10. \text{ kN}$$

Total capacity of connections

$$\phi V_{d2} = \phi V_{d2t} + \phi V_{d2b} + \phi V_{d2l} + \phi V_{d2r}$$

$$= 50. + 190. + 67. + 10.$$

$$= 318. \text{ kN}$$

One-way action

Length supported by the top connection

$$L_{con1t} = 6,600 \text{ mm}$$

Length supported by the base connection

$$L_{con1b} = 6,600 \text{ mm}$$

Total length supported by the connections

$$L_{con1} = L_{con1t} + L_{con1b}$$

$$= 6,600 + 6,600$$

$$= 13,200 \text{ mm}$$

Area supported by top connection

$$A_{con1t} = H. L. L_{con1t} / L_{con1} / 10^6$$

$$= 3,800 \times 6,600 \times 6,600 / 13,200 / 10^6$$

$$= 12.5 \text{ m}^2$$

Area supported by base connection

$$A_{con1b} = H. L. L_{con1b} / L_{con1}$$

$$= 3,800 \times 6,600 \times 6,600 / 13,200 / 10^6$$

$$= 12.5 \text{ m}^2$$

Total area supported connections

$$A_{con1} = A_{con2t} + A_{con2b}$$

$$= 12.5 + 12.5$$

$$= 25.1 \text{ m}^2$$

Capacity of top connection

$$\phi V_{d1t} = \phi V_{dt} A_{con1t}$$

$$= 6.3 \times 12.5$$

$$= 79. \text{ kN}$$

Capacity of base connection

$$\phi V_{d1b} = \phi V_{db} A_{con1b}$$

$$= 23.8 \times 12.5$$

$$= 299. \text{ kN}$$

Total capacity of connections

$$\phi V_{d1} = \phi V_{d1t} + \phi V_{d1b}$$

$$= 79. + 299.$$

$$= 378. \text{ kN}$$

## Appendix D

### Fire Performance

#### Fire Test Performance

A standard fire performance test has been carried out by the CSIRO, in accordance with AS 1530.4.

CSIRO Report	FSV 1266
CSIRO Certification of Test	2042
Wall tested	200 mm Benex (600 x 200 x 200 mm wide with hollow cores)
Wall Dimensions	
Height	3,000 mm
Length	3,000 mm
Thickness	200 mm
Material Thickness	
Test Conditions	
Vertical load	224 kN over 3.0 m wall length (72 kN/m)
Side support	Nil
Slenderness	11.25 (Based on AS 3700 Section 6)
Time to failure	
Structural Adequacy	No failure at 241 minutes
Integrity	No failure at 241 minutes
Insulation	Failure at 198 minutes

#### Interpretation of Fire Test Data

Fire performance data determined below, used to support designs to BCA Volume 1 Part C or BCA Volume 2 Part 3.7, is based on:

- CSIRO Fire Test Report - FSV 1266
- AS 3700 Section 6

When subjected to the standard fire test of AS 1530.4, the 200 mm hollow Benex Masonry wall demonstrated a high degree of performance, in excess of that expected of similar concrete masonry products.

- Standard test outputs:

Structural Adequacy	No failure at 241 minutes
Integrity	No failure at 241 minutes
Insulation	Failure at 198 minutes
- The deflection varied approximately linearly from 0 to approximately 19 mm (9.5 % of the thickness), at the time when the test was terminated (241 minutes), without showing any sign of the rapid expansion associated with siliceous aggregates.

Structural Adequacy

If a wall were constructed (say) 4.0 metres high, the slenderness would be  $0.75 \times 4000 / 200 = 15.0$  (the limit given in AS 3700 Table 6.1 for normal concrete masonry at 240 minutes).

The deflection at the centre would most likely be of the order of 30 mm (i.e. 15% of the thickness).

Collapse under fire load would normally be expected to occur as the deflection approaches 80% of the thickness. In other words, collapse is very unlikely to occur even at this slenderness. Therefore, it can be reasoned that the behaviour of 200 mm Benex Masonry appears to be superior to that of conventional masonry of similar slenderness. It is therefore both reasonable and conservative to design Benex Masonry walls using the slenderness limits of AS 3700 Table 6.1 for normal concrete masonry, which are reproduced below.

<b>Benex Masonry Slenderness Limits Fire Resistance Levels for Structural Adequacy</b>						
Fire Resistance Level (minutes)	30	60	90	120	180	240
Slenderness Limit Unreinforced Benex Masonry	19.5	18.0	17.0	16.0	15.5	15.0
Slenderness Limit Reinforced Benex Masonry	36.0	36.0	36.0	36.0	36.0	36.0
Note These slenderness limits are drawn from AS 3700 Table 6.1 for concrete masonry with less than 45% basalt.						

Integrity

Based on the CSIRO test, the Fire Resistance Level for 200 mm Benex Masonry is 240 minutes.

Insulation

Based on the CSIRO test, the Fire Resistance Level for 200 mm Benex Masonry is 180 minutes.

### Kerry add Certificate

## Appendix E

### Acoustic Performance

#### Airborne Sound Transmission of Benex Masonry

CSIRO Report TL474 provides the following airborne sound insulation test results and interpretations, carried out in accordance with:

- AS 1191:2002 for method of laboratory measurement of airborne sound insulation of building elements
- AS 1276:1979 and ISO 717.1: 2004 for the rating of sound insulation (Sound Transmission Class, STC, and Weighted Sound Index,  $R_w$ ) in buildings

Airborne Sound Transmission of Benex Masonry		
System	$R_w$	C; $C_{tr}$
200 mm hollow Benex Masonry	37	-1; -3
200 mm hollow Benex Masonry + Resilient clips + Plasterboard on one side	37	0; -3
200 mm hollow Benex Masonry + Resilient clips + Plasterboard on one side + 100 mm solid Benex Masonry veneer leaf	52	-1; -5

### Kerry Add Certificate

## Appendix F

### Thermal Performance

#### Thermal Conductivity of Benex Material

BRANZ Test Report EC1310 (4<sup>th</sup> May 2007) reports the thermal conductivity,  $k$ , of a 600 x 600 x 50 mm sample of Benex material to be  $0.45 \pm 0.02$  W/m.K, measured using the BRANZ Heat Flow Apparatus.

#### Thermal Resistance of Benex Masonry

BRANZ Test Report EC1310 (4<sup>th</sup> May 2007) also provides the following data for the thermal resistance of 200 mm hollow Benex Masonry, derived from samples tested in a Guarded Hot Box apparatus in accordance with ASTM C1363-97. The measured air-to-air thermal resistance ( $R$ ) of the test was  $0.46 \pm 10\%$  m<sup>2</sup>K/W. This includes an estimated total surface resistance of  $0.10$  m<sup>2</sup>K/W. By subtracting the total surface resistance from the air-to-air thermal resistance, the surface to surface thermal resistance,  $R$ , of  $0.36 \pm 10\%$  m<sup>2</sup>K/W can be determined.

#### Theoretical Confirmation of the Measured Values

The theoretical thermal resistance of 200 mm hollow Benex Masonry can be derived using the following method. It can be seen that the calculated value of  $R = 0.35$  m<sup>2</sup>K/W is very close to the guarded hot-box measured value of  $0.36$  m<sup>2</sup>K/W.

Thermal Resistance of 200 mm hollow Benex Masonry			
Thermal conductivity of face shells	$k_f$	0.450	W/m.K
Thermal conductivity of webs	$k_w$	0.450	W/m.K
Thermal conductivity of cores	$k_c$	0.026	W/m.K
Block length	$l$	600	mm
Block height	$h$	600	mm
Block width	$t$	200	mm
Joint thickness	$t_j$	0	mm
Outer face shell	$t_{so}$	44	mm
Inner face shell	$t_{si}$	44	mm
Web 1 thickness	$w_1$	44	mm
Web 2 thickness	$w_2$	44	mm
Web 3 thickness	$w_3$	38	mm
Number of cores	$N$	2	mm
Core length	$l_c$	237	mm
Core width	$t_c$	112	mm
Equivalent thickness	ET	112	mm
Resistance of webs	$R$	0.249	m <sup>2</sup> .K/w
Resistance of cores	$R$	0.140	m <sup>2</sup> .K/w
Effective resistance of cores/webs/joint space	$R_{c,w,i}$	0.154	m <sup>2</sup> .K/w
Resistance of outer face shell	$R_o$	0.098	m <sup>2</sup> .K/w
Resistance of inner face shell	$R_i$	0.098	m <sup>2</sup> .K/w
Total Thermal Resistance (surface to surface)	$R$	0.350	m <sup>2</sup> .K/w

### Kerry Add Certificate. Perhaps add Aircell certificate (See previous comments on Aircell)

## Appendix G Detailing

### Scope

This appendix quotes the relevant tests, which substantiate the recommendations regarding structural support, resistance to water penetration and durability.

### Structural Supports - Test Report

CSIRO Report No DTS767 (30/10/07) sets out the structural tests that demonstrate the behaviour of Benex Masonry subject to vertical and horizontal loads. In each case the tests assume rigid supports. The worked example in Appendix C shows the means of calculation for connection strength.

### Weather-proofing - Test Report

CSIRO Report No DTS767 (30/10/07) paragraph 5.05 states that properly built Benex masonry walls can resist the conditions imposed by the ASTM water permeability test for more than 24 hours, without failure. In general, rendered Benex masonry walls can be considered as impervious without further protection since any tiny holes in joints can be fully covered with render.

### Durability to Salt Exposure - Test Report

CSIRO Report No DTS767 (30/10/07) paragraph 5.14 states that both solid and hollow Benex blocks can be categorised as “Exposure Grade” as per AS/NZS 4456.10:1997, and that they can be used in aggressive environments such as “severe marine environments” and “aggressive soils”, as per AS 3700 Clause 5.2.5. The report notes that salt diffusion occurs only through open (cut) surfaces, and that capped surfaces seem impermeable towards salt movement.

## Kerry Add certificates

## Appendix H Specifications

### Scope

This sample specification covers the construction of Benex Masonry in buildings, including unreinforced and reinforced walls, piers and lintels.

This sample specification are available in electronic format, with the express intention that designers will edit them to suit the particular requirements of specific construction projects. The design, construction and costing of structures must be carried out by qualified and experienced architects, engineers and builders. This sample specification has been prepared in the context of the Building Code of Australia. Architects, engineers and builders should make themselves aware of any recent changes to these documents, to any Standards referred to therein or to local variations or requirements. The authors, publishers and distributors of this specification and the associated details do not accept any responsibility for incorrect, inappropriate or incomplete use of this information.

To prepare a working specification for a particular contract, obtain an electronic version, and edit as appropriate.

### Building Code of Australia and Standards

All materials and construction shall comply with the most recent version of:

- the relevant parts of the Building Code of Australia;
- the Standards referred to therein;
- other Standards nominated in this specification; and
- other relevant Regulations.

#### Relevant Standards and Documents

CSIRO Report No DTS767 (30/10/07)

AS 3700 Masonry structures

AS/NZS 4455 Masonry units and segmental pavers

AS/NZS 4456 Masonry units and segmental pavers - Methods of test

AS/NZS 2904 Damp-proof courses and flashings

AS/NZS 2699.1 Built-in components for masonry construction - Wall ties

AS/NZS 2699.2 Built-in components for masonry construction - Connectors and accessories

AS/NZS 2699.3 Built-in components for masonry construction - Lintels and shelf angles durability

AS 3660.1 Termite management – New Building work

AS 3660.2 Termite management – In and around existing buildings and structures - Guidelines

AS/NZS 4680 Hot-dip galvanised (zinc) coatings on fabricated ferrous articles

AS/NZS 4534 Zinc and zinc/aluminium-alloy coatings on steel wire

AS 2837 Wrought alloy steels – stainless steel bars and semi-finished products

AS/NZS 4792 Hot-dip galvanised (zinc) coatings on ferrous hollow sections, applied a continuous or specialised process

AS/NZS 4791 Hot-dip galvanised (zinc) coatings on ferrous open sections, applied by an in-line process

AS/NZS 4671 Steel reinforcing materials

AS 1397 Steel sheet and strip

AS 3600 Concrete structures

AS 2870 Residential slabs and footings – Construction

### Commencement

Work shall commence as soon as practical after, but not before,

(a) The Builder has issued:

- a written order
- the relevant contract drawings, specifications and schedule of work
- written approval of any details provided by the Contractor

(b) Completion of supporting structures such as footings, concrete slab-on-ground or suspended concrete slabs.

**Masonry Units**

Masonry units shall be Benex masonry units complying with the Drawings, Building Code of Australia, relevant Standard (AS/NZS 4455.1) and the manufacturer's specification. Properties shall be not less than:

- Masonry units shall comply with Dimensional Category DW4, except that split or irregular faces may be DW0. (DW4 is more stringent than the commonly specified DW1).
- Masonry units shall meet General Purpose Salt Attack Resistance Grade, except for applications requiring Exposure Grade. Applications requiring Exposure Grade are:
  - saline wetting or drying,
  - aggressive soils,
  - severe marine environments,
  - saline or contaminated water including tidal or splash zones, or
  - within 1 km of a industry producing chemical pollutants
- Masonry units shall have a Characteristic Compressive Strength not less than 4.0 MPa in 200 mm hollow masonry units.

**Notes**

1. For hollow units, compressive strength is measured using face shell bedding.
  2. Values for the minimum characteristic compressive strength shall be confirmed by the Design Engineer, who should check with the manufacturers the availability of particular strength grades.
- Masonry units intended for face applications and exposed to the weather shall have:
    - Permeability not more than 2 mm/minute
    - Efflorescence Potential of Nil or Slight
    - Colour and texture within an agreed range.
  - Masonry units intended for exposure to lateral loads in excess of 0.5 kPa shall have a Characteristic Lateral Modulus of Rupture not less than 1.2 MPa for 200 mm hollow masonry units.
  - Masonry units shall have a Mean Coefficient of Residual Drying Contraction not more than 0.6 mm/m.
  - Masonry units for reinforced masonry applications shall have the following properties:
    - Units may be fully grouted and may be reinforced both vertically and horizontally;
    - Grout may flow easily around and enclose the reinforcement in all cores; and
    - Cover is consistent with the requirements for durability, strength and fire resistance as appropriate

**Benex Masonry Units**

Benex Masonry units have been demonstrated to comply with the abovementioned specification, as per CSIRO Report No DTS767 (30/10/07)

**Definitions**

- Dimensional Category DW0 - No Requirements
- Dimensional Category DW1 - Average deviation of a sample of 20 units; +, - 2.5 mm (dimensions under 150 mm); +, - 4.5 mm (dimensions 150 to 250 mm); +, - 5.0 mm (dimensions over 250 mm)
- Dimensional Category DW4 - For a sample of 20 units, the standard deviation of work sizes shall be not more than 2 mm, and the difference between the mean and the work size shall be not more than 3 mm. For split faces, the dimensional deviations shall not apply to the width of the unit, provided the average width is not less than 90% of the work size.
- General Purpose Salt Attack Resistance Grade - Performance such that it is possible to demonstrate that the product has a history of surviving under non-saline environmental conditions similar to those existing at the site considered, but not expected to meet the mass loss criterion for Exposure Grade Salt Attack Resistance Grade.
- Exposure Grade Salt Attack Resistance Grade - Performance such that it is possible to demonstrate that the product has a history of surviving under saline environmental conditions similar to those existing at the site considered; and less than 0.2 grams mass loss in 40 cycles in AS/NZS 4456.10, Method B test.

**Concrete Grout**

Concrete grout shall comply with the Drawings, Building Code of Australia and relevant Standard (AS 3700). Unless stated otherwise, properties shall be:

- a minimum portland cement content of 300 kg/cubic metre;
- a maximum aggregate size of 10 mm;
- sufficient slump to completely fill the cores
- pumpable; and
- a minimum compressive cylinder strength of 20 MPa.

**Joint Material**

Joint material shall comply with the Drawings, Building Code of Australia and relevant Standard (AS 3700). Unless stated otherwise:

- Backing rod for control joints, expansion joints and articulation joints shall be expanded polystyrene tube or bead or, rigid steel backing profile with closed cell foam adhered to the metal profile face.
- Joint sealant shall be gun grade multi-purpose polyurethane sealant.
- Control joints and articulation joints shall incorporate de-bonding tape.

Intumescent seals shall be acrylic co-polymer sealant capable of providing the requisite fire performance as specified in the Drawings and/or Building Code of Australia as appropriate.

**Slip Joint Material**

Slip joint material shall comply with the following requirements. Metal slip joint materials shall not be used in locations that are subject to rising salt damp.

- Bitumen-coated aluminium
- Embossed polyethylene
- Polyethylene-and-bitumen coated aluminium.

**Adhesive**

Adhesive shall be Benex adhesive (or equivalent approved by the manufacturer), mixed and applied in accordance with the manufacturer's instructions. Capping blocks and other fittings shall be fixed using screws and polyurethane adhesive.

**Termite Protection**

Termite protection measures shall comply with the Building Code of Australia and the relevant Standard (AS 3660.1)

The aim of most termite barriers is to force the termites to the surface of the structure, where they are visible and can be easily eradicated. Some termite barriers also include chemicals that deter the termites from passing. Other systems, involving chemical dosing and graded stone barriers may be applicable, but must be properly maintained. Refer to the relevant materials specifications.

Termite protection shall provide a continuous barrier that prevents termites from entering the building undetected. The critical areas for termite entry, including the external perimeter, construction joints and plumbing penetrations, shall be protected and treated by a termite management system. The system installation shall conform to the manufacturer's guidelines.

A manufacturer's warranty for a minimum of fifty (50) years shall be provided. The warranty shall be renewable on an annual basis, base on annual inspection by the system installation organisation. Such a warranty shall provide for timber replacement should a system breach occur.

A certificate permanently fixed to the building in a prominent location, such as a meter box, kitchen cupboard, or similar, shall indicate the following:

- Method of protection.
- Date of installation.
- Life expectancy of any termiticide and the required re-injection date.
- Installer's or manufacturer's recommendations for the scope and frequency of future inspections for termite activity, not greater than 12 months.

Sheet material acting as a termite barrier within the masonry and their joints shall be constructed of termite-resistant materials, such that termites are unable to pass through them. The maximum aperture size of a perforated sheet material barrier shall be sufficiently small as to deny access to foraging termite species of the region. Combinations of materials likely to cause electrolytic reaction shall not be used, e.g. stainless steel mesh shall not be used in contact with mild steel reinforcement.

### Slip Joints

Slip joint material shall be placed between unreinforced masonry walls and any supported concrete slab.

### Lintels and Arch Bars

Lintels and arch bars shall be built in over openings in excess of 1.0 metre accordance with the Drawings, Building Code of Australia and relevant Standard (AS 3700).

### Anchorage

Anchorage, including those to tie down roof structures, shall be installed at specified locations; and in accordance with the Drawings, Building Code of Australia and relevant Standard (AS 3700).

### Control Joints and Articulation Joints in Unreinforced Benex Masonry

Vertical control joints or articulation joints shall comply with the Drawings, Building Code of Australia and relevant Standard (AS 3700). Unless stated otherwise, vertical control joints or articulation joints shall be built into Unreinforced Benex Masonry at the following locations:

- Centres not exceeding the following in straight continuous walls without openings

For sand and rock sites (Class A); and slightly reactive sites (Class S), with little or no ground movement from moisture changes –

Articulation is not required

For moderately reactive clay or silt sites, which can experience moderate ground movement from moisture changes (Class M or MD) and highly reactive clay sites, which can experience high ground movement from moisture changes (Class H or H-D) –

External masonry face finish, rendered or painted	7.0 m
Internal masonry sheeted and/or face finished	6.0 m
Internal masonry rendered and/or painted	5.0 m

- Not closer than the height of the wall away from corners
- Not more than 5 metre centres in a wall with openings more than 900 x 900 mm, and positioned in line with one edge of the opening
- At the position where a wall changes height by more than 20%
- At a change in thickness of a wall
- At control joints or construction joints in supporting slabs
- At the junctions of walls constructed of different masonry materials
- At deep rebates
- At a distance from all corners not less than 500 mm and not greater than 3000 mm.

Articulation and control joints shall not be placed adjacent to arches. Control joints in concrete masonry arches shall be saw-cut to half the depth of the masonry unit and positioned at the centre of the arch.

Control joints and articulation joints, shall be 10 mm wide and shall consist of a polystyrene backing rod and a polyurethane material gunned into the joint to form a 10 x 10 mm flexible seal. The backing rod shall be placed into the masonry at a depth, which permits the finish of the control joints to match the joints.

For control joints or articulation joints in cavity walls (i.e. not in veneer walls), extendible masonry ties shall be built into every fourth course.

Where an articulation joint is adjacent to a door or window frame, a 10 mm gap shall be provided between the edge of the frame and the masonry to allow for movement.

**Additional Requirements for Reinforced Masonry Construction (Excluding Retaining Walls)**

All construction of reinforced concrete masonry shall comply with the Drawings, Building Code of Australia and relevant Standard (AS 3700). Unless stated otherwise, the following shall apply:

- Vertical steel reinforcement shall be tied using tie wire to steel starter bars through clean-out holes in each reinforced core and fixed in position at the top of the wall by plastic clips or template. Starter bars shall be tied into position to provide the specified lap above the top surface of the footing. The starter bars shall be held in position on the centre line of a reinforced blockwork wall by a timber member or template and controlled within a tolerance of  $\pm 5$  mm through the wall and  $\pm 50$  mm along the wall.
- Horizontal steel may be laid in contact with rebated webs of blocks. It shall be held in position by steel ties or plastic clips. Cover to horizontal steel in lintel blocks shall be maintained by the use of wheel type plastic clips.
- The minimum cover (from the edge of the steel reinforcement to the inside face of the block core) shall be 20 mm, except where specified otherwise. In severe marine environments, saline or contaminated water including tidal and splash zones, and within 1 km of an industry in which chemical pollutants are produced, the minimum cover to the inside face of the block core shall be 30 mm.
- Control joints shall be built into reinforced concrete masonry at all points of potential cracking and at the locations shown on the drawings. The spacing of control joints should not exceed 9.0 metres or as specified.

## Occupational Health and Safety

The following table sets out the principal considerations of occupational health and safety for the construction of Benex Masonry.

<p><b>Activities Covered by these Procedures</b>          Receive all materials required for Benex Masonry construction onto the site and store off the ground in a safe, secure location.          Move the materials to work site.          Lay Benex Masonry, including joint adhesive          Tie reinforcement, blank off and concrete grout (where required)          Fill vertical control joints</p>	
<p><b>Limitations:</b> The worker is <u>not</u> authorized to:</p> <ul style="list-style-type: none"> <li>• Use electrical equipment, welding equipment and the like</li> <li>• Use motorized equipment, except elevators and mixers</li> </ul>	
<b>Risks</b>	<b>Precaution</b>
Impact by mobile equipment	Wear brightly coloured shirt or vest
Impact from falling items	Wear a safety helmet near elevated work
Back injury or muscle injury	Do not lift heavy items – max 14 kg Avoid strenuous activity if unfit or suffering back or muscle strain
Foot injury	Wear strong boots, preferably with steel caps
Heat exhaustion	Drink plenty of fluids, Rest in shaded areas
Sun damage to skin	Wear a hat, shirt & sunscreen
Fall from ladder	Ensure top of ladder is secured & protruding at least 1.0 m above the floor
Electrocution	Ensure electrical equipment is safe & tagged Do not use electric power in wet conditions Wear insulated footwear Avoid overhead & hidden power cables
Fall from scaffold, roofs or elevated floors	Ensure all handrails are installed Do not lean on handrails
Chemical attack to skin by cement in concrete grout, in some cases leading to dermatitis	Wear gloves and other protective clothing to avoid rash and itchiness
Inhalation of dust, particularly while cutting masonry	Wear respirators complying with AS/NZS1715 and AS/NZ1716, and eye protection, complying with AS1336, when cutting and chasing masonry.
Collapse of structure	Ensure structure is correctly braced. In particular, ensure that unfinished masonry not tied to permanent supports is braced.

# Kerry to delete Appendix I

## Appendix I Sustainability

### Part 1 – Sustainability Assessment Methodology

The sustainability of Benex Masonry has been assessed in accordance with the ENVIROSPEC Protocol. The purpose of this Protocol is to define practical methodologies for classifying building products, such that their contribution to sustainability is easily identifiable. For purposes of this Protocol, sustainability is taken as those properties that lead to:

- Reduction in green-house gas generation, which causes global warming;
- Reduction in the use of non-renewable resources upon which our society depends; and
- Reduction in land, water or air pollution or degradation, which alienates the use of these resources.

It is recognised that the comparison of comprehensive life cycle analyses, prepared for competing products, is the most equitable basis of selecting sustainable products. However, comprehensive life cycle analyses are controversial, because they involve numerous assumptions regarding the manufacture, transport, construction, demolition and re-use of the building products; and assumptions regarding their in-service performance.

To date, Building Regulations have concentrated on only some aspects of in-service performance (e.g. specifying levels of insulation to achieve desired energy minimisation). The process of preparing such regulations has highlighted the problems in assessing the in-service performance of various products in various applications. (e.g. Differing thermal resistance and thermal mass of various building products will contribute differently to energy minimisation in different climates and different building types.)

Reflecting the current approach of building regulators, Part 2 of this Protocol considers the special circumstances of in-service performance criteria, in isolation from the other life-cycle considerations. It deals with the effects of a building product on the sustainable operation of the building into which it is built, in the context of what is both common practice and what is permissible under the Building Regulations. It provides for:

- Collection of data for subsequent use in life-cycle analysis; and
- Methods of classifying building products by their in-service effect in specific applications.

Once in-service data is gathered by the methods described in Part 2, it may be used as one of the inputs into a comprehensive life-cycle analysis used to produce Environmental Declarations. Such declarations should account for the sustainability impacts of the manufacture, transport, construction, demolition and re-use of building products, together with their in-service performance. They should comply with ISO/DIS 21930 as described in Part 1 of the Protocol. The following extracts from ISO/DIS 21930 provide context for Environmental Declarations in accordance with Part 1 of the Protocol.

*If possible, Type III declarations for building products should account for all life cycle stages of the product. Omissions of life cycle stages shall be justified. Where not all the necessary information is available, the PCR shall state those stages that are to be addressed and how to deal with information gaps. The declarations may be based on generic data, as defined in the PCR.*

*Environmental impacts, e.g. energy and materials used, resulting from the installation of the building product in the building shall be identified and included in the report. If it is not included, because data is not available, this fact shall be stated.*

## Part 2 - Embodied Energy and Heating and Cooling Energy Associated with Benex Masonry in Australian Buildings - Housing

### Background

The BCA (Building Code of Australia) sets out the performance requirements for energy saving in Australian buildings<sup>3</sup>, and some DTS (deemed-to-satisfy) forms of construction. Both the performance requirements and the DTS provisions are based on minimising heating and cooling energy, and do not give requirements for minimising the embodied energy used to manufacture the building components.

### Scope

This Appendix provides estimates of the embodied energy used to manufacture Benex Masonry wall systems, and compares it to a selected benchmark (clay masonry veneer), commonly used in Australian housing. From this data, the savings in embodied energy to change from the benchmark system to Benex Masonry can be calculated, and this information can be expressed as a percentage of the heating and cooling energy over the life of the house.

### Form of Construction

Benex Masonry is often constructed as single-leaf masonry with large roof overhangs. However, if Benex Masonry walls are designed in accordance with BCA Volume 2 Part 3.12 Deemed-to-Satisfy energy provisions or NSW BASIX provisions, the use of a veneer system could be preferable to single leaf. For this reason, both Benex Masonry single leaf walls and Benex Masonry veneer walls have been analysed in this report.

### Limitations

This is a preliminary study based on a limited amount of information, and should be augmented by a more comprehensive study. It does not consider credits for reuse of materials during the final demolition. Nor does it include painting and maintenance of non-face-brick components.

### Analysis

- Table 1 shows the embodied energy of various masonry systems, including clay masonry veneer, Benex Masonry single leaf and Benex Masonry veneer. Embodied energy values are expressed as MJ/m<sup>2</sup> of wall area.
- Table 2 shows the embodied energy saving to change construction from clay brick veneer to Benex Masonry single leaf or Benex Masonry veneer.

### Conclusions

- Table 1 shows that the embodied energies of Benex Masonry Single Leaf wall system (with grouted cores at 2.4 m centres) consumes slightly more embodied energy and Benex Masonry Veneer wall system consumes slightly less embodied energy than the selected benchmark construction (clay masonry veneer).
- Table 2 shows that the small changes (positive or negative) in embodied energy, resulting from changing construction from the clay brick veneer benchmark to Benex Masonry, are insignificant when compared with the target operational 5 Star heating and cooling energy expended over the life of the building.

<sup>3</sup> In this Appendix, the comparisons are made for housing complying with BCA Volume 2.

**Table 1 - Embodied Energy of Various Masonry Systems**

Climate Zone	Embodied Energy MJ/m <sup>2</sup> wall		
	Clay Masonry Veneer	Benex Masonry Single Leaf	Benex Masonry Veneer
1 Hot humid warm winter	590	672	498
2 Warm humid summer, mild winter	590	672	498
3 Hot dry summer warm winter	590	672	498
4 Hot dry, cool winter	590	672	498
5 Warm temperate	590	672	498
6 Mild temperate	590	672	498
7 Cool temperate	590	672	498
8 Alpine area	610	728	519

Notes:

- The insulation of all systems is in accordance with the BCA-2006 Volume 2 requirements and the corresponding Deemed-to-Satisfy details.
- Tabulated values are the sum of the embodied energies of the principal components making up the wall.

**Table 2 - Embodied Energy Saving to Change Construction From Clay Brick Veneer To Benex Masonry Single Leaf or Benex Masonry Veneer**

Climate Zone	5 Star Heating & Cooling Energy (MJ/m <sup>2</sup> wall over life)	Embodied Energy Reduction, if construction is changed from Clay Masonry Veneer to Benex Masonry			
		MJ/m <sup>2</sup> wall		% of Heating & Cooling Energy over life of building)	
		Benex Masonry Single Leaf	Benex Masonry Veneer	Benex Masonry Single Leaf	Benex Masonry Veneer
1 Hot humid warm winter	24,624	84	-90	<b>0.3%</b>	<b>-0.4%</b>
2 Warm humid summer mild winter	6,926	84	-90	<b>1.2%</b>	<b>-1.3%</b>
3 Hot dry summer, warm winter	10,004	84	-90	<b>0.8%</b>	<b>-0.9%</b>
4 Hot dry, cool winter	12,697	84	-90	<b>0.7%</b>	<b>-0.7%</b>
5 Warm temperate	8,465	84	-90	<b>1.0%</b>	<b>-1.1%</b>
6 Mild temperate	14,236	84	-90	<b>0.6%</b>	<b>-0.6%</b>
7 Cool temperate	19,238	84	-90	<b>0.4%</b>	<b>-0.5%</b>
8 Alpine area	16,545	116	-93	<b>0.7%</b>	<b>-0.6%</b>

Notes:

The insulation of all systems is in accordance with the Draft BCA-2006 Volume 2 requirements and the corresponding Deemed-to-Satisfy details.

Positive values in this table indicate that the particular system (Benex Masonry Single Leaf) has consumed more embodied energy than the corresponding clay masonry veneer system.

Negative values in this table indicate that the particular system (Benex Masonry Veneer) has consumed less embodied energy than the corresponding clay masonry veneer system.

## Methodology

The methodology employed herein is as follows. For a range of common Australian house building components in each Climate Zone:

1. From published data, determine the embodied energy per unit mass of common building components.
2. Determine the mass and embodied energy of each selected component and its most common alternatives
  - Benex Masonry single leaf wall
  - Benex Masonry veneer wall
  - Clay brick veneer wall (benchmark construction)
3. Determine the embodied energy difference, to change to the principal component from the benchmark form of construction.
4. Using the ABCB Protocol energy software, determine the target heating and cooling energy consumption for each relevant location.<sup>4</sup>
5. Compare the embodied energy difference (to change from the principal component to the alternative form of construction) to target 5 star heating and cooling energy consumption.<sup>5 6</sup>

**Criterion: “ have lower embodied energy than commonly available alternatives.”**

### Benchmark

For external walls, the “commonly used alternatives” referred to in this statement are:

Clay masonry veneer walls, consisting of 230 x 76 x 110 mm extruded clay bricks, set in 1:1:6 mortar, supported by 70 mm MGP10 timber stud wall, with 10 mm plasterboard lining and incorporating bulk insulation nominated in BCA Volume 2 Part 3.12.

Climate Zone	Embodied Energy (MJ/m <sup>2</sup> wall) for Clay Masonry Veneer
1 Hot humid warm winter	590
2 Warm humid summer, mild winter	590
3 Hot dry summer, warm winter	590
4 Hot dry, cool winter	590
5 Warm temperate	590
6 Mild temperate	590
7 Cool temperate	590
8 Alpine area	610

<sup>4</sup> A more sophisticated approach is to analyse each house design using conforming software (e.g. AccuRATE). However the approach used in this paper is considered to be more appropriate for comparing embodied energies, since most houses will suffer various limitations of site orientation, shading etc. and will probably only “just” achieve the required energy consumption defined in the ABCB Protocol.

<sup>5</sup> The “savings” are expressed as a percentage of the Heating and Cooling energy, calculated using the ABCB Protocol for House Energy Rating Software Version 2006.1.

<sup>6</sup> The calculated values for embodied energy are considered to be very low proportions of heating and cooling energy. Total life-cycle energy of a house is much higher (7 to 8 times higher) than the heating and cooling energy. If embodied energy saving were treated as a proportion of total life-cycle energy rather than of heating and cooling energy, the proportions would go from very small to insignificant. This suggests that there are far more significant savings in energy and greenhouse gas emissions to be made through controlling house operational energy (appliances etc) than by attempting to control embodied energy of the building fabric.

**Compliance:**

Compliance with this criterion shall be substantiated by evidence that the product has Embodied Energy less than the benchmark clay masonry veneer walls.

**Benex Masonry Manufacturing Process**

The manufacturing process consists of the following:

- A steel mould of the appropriate external dimensions is inserted into the machine.
- A sand/cement slurry is sprayed into a mould, to provide a dense coating approximately 2 mm thick.
- The steel plugs, used to form the cores of the hollow blocks, are inserted into the mould.
- The core mix is inserted and compacted to the required density.
- A coating on envirospheres and cement is sprayed on the back of the block to seal the surface.
- The blocks are cured in the moulds for approximately four hours. The blocks may be air-cured in a warm or temperate climate, but in a cold climate they may need to be dried in a warmed drying room of temperature approximately 28°C.

**Embodied energy per unit mass of common building components**

The embodied energy of particular building materials depends in part on the country of origin and the process involved in manufacture. There are many sources of information on embodied energy of materials, some of which are available on the Internet. The following have been chosen for use in this report.

Estimated Embodied Energy of Common Building Components			
Material	Approximate Density, kg/m <sup>3</sup>	Embodied Energy <sup>1</sup> MJ/kg	Embodied Energy MJ/ m <sup>3</sup>
Benex Masonry blocks	1,000	4.0 <sup>Note 3</sup>	4,000
Brick (clay)	1,700	2.5 <sup>Note 1, 2</sup>	4,250
Concrete	2,360	1.9	4,480
Plasterboard	880	6.1	5,368
Kiln dried, dressed timber	510	2.5	1,280
Fibreglass Insulation	18	30.3	550
Polystyrene Insulation	16	117	1,870
Sand & aggregate	1,700	0.8	1,360
Cement	1,500	5.6	

## Notes

1. For consistency of comparisons, the values of embodied energy per unit mass of common building components have all been drawn from a common source. This is considered to be the most appropriate approach, notwithstanding that the use of energy in the manufacture of products varies from plant to plant.
2. The Benex Masonry embodied energy is determined in the following way. Density 1,000 kg/m<sup>3</sup>

Constituent	% by weight	Embodied Energy MJ/kg
Off-white cement	34.2%	1.92
Fine sand	46.1%	0.37
Polystyrene beads (2-3 mm)	1.3%	1.57
Water	18.3%	0.00
<u>Other processes</u>	<u>0%</u>	<u>0.15</u>
Calculated Total	100.0%	4.00

### Typical Relationship between Net Area of External Wall and Floor Area of Habitable Rooms

The values tabulated below are the prescribed limits on energy consumption for the total of heating and cooling per unit floor area of habitable room. This area is different from the net area of external wall (which incorporates the wall embodied energy).

The relationship between net area of external wall and floor area of habitable rooms depends on the building dimensions, window and door areas, proportion of habitable to non-habitable rooms and height of sub-floor. The relationship could also vary a little depending on whether the house is one or two storey, although this effect is minor provided suitable adjustment to the other inputs is made.

The following calculations determine a typical relationship between net area of external wall and floor area of habitable rooms, and will be used in subsequent calculations.

Typical Relationship Between Net Area of External Wall and Floor Area of Habitable Rooms		
Length	15.0	m
Width	10.0	m
Floor to ceiling height	2.4	m
Subfloor height	0.3	m
Total wall height	2.7	m
Proportion habitable floor	15%	
Windows & door area (Including jambs, sill etc)	36	m <sup>2</sup>
Internal gross wall area (including windows & doors)	120	m <sup>2</sup>
(Windows + doors) / Wall	30%	
Net external wall area (based on total wall height)	99	m <sup>2</sup>
Habitable floor area	128	m <sup>2</sup>
Net external wall area / Habitable floor area	77%	

## Target 5 Star Heating and Cooling Energy Consumption

Target Heating and Cooling Energy to Achieve 5 Star Performance MJ/m <sup>2</sup> based on <u>Habitable Floor Area</u>				
Zone	Representative City		5 Star Annual Energy Limit MJ/m <sup>2</sup>	5 Star Lifetime Energy Limit MJ/m <sup>2</sup>
1 Hot humid warm winter	Darwin	1	320	19,200
2 Warm humid summer, mild winter	Brisbane	10	90	5,400
3 Hot dry summer, warm winter	Alice Springs	6	130	7,800
4 Hot dry, cool winter	Tamworth	14	165	9,900
5 Warm temperate	Sydney (East)	17	110	6,600
6 Mild temperate	Melbourne	21	185	11,100
7 Cool temperate	Hobart	25	250	15,000
8 Alpine area	Alpine	26	215	12,900

Notes

- Annual energy limit from ABCB Protocol Building Energy Analysis Software Version 2005.1 May 2005.
- The energy consumption values are total of heating and cooling per unit floor area of habitable rooms.
- Lifetime energy limit is based on 60 years building life.

Target Heating and Cooling Energy to Achieve 3 or 5 Star Performance MJ/m <sup>2</sup> based on <u>Net External Wall Area</u>				
Zone	Representative City		5 Star Annual Energy Limit MJ/m <sup>2</sup>	5 Star Lifetime Energy Limit MJ/m <sup>2</sup>
1 Hot humid warm winter	Darwin	1	410	24,624
2 Warm humid summer, mild winter	Brisbane	10	115	6,926
3 Hot dry summer, warm winter	Alice Springs	6	167	10,004
4 Hot dry, cool winter	Tamworth	14	212	12,697
5 Warm temperate	Sydney (East)	17	141	8,465
6 Mild temperate	Melbourne	21	237	14,236
7 Cool temperate	Hobart	25	321	19,238
8 Alpine area	Alpine	26	276	16,545

Notes

- Annual energy limit from ABCB Protocol for Building Energy Analysis Software Version 2005.1 May 2005.
- The energy consumption values are total of heating and cooling per unit net external wall area of habitable rooms.
- Lifetime energy limit is based on 60 years building life.



ABN 31 088 338 532 Inc in NSW  
[www.electronicblueprint.com.au](http://www.electronicblueprint.com.au)  
[info@electronicblueprint.com.au](mailto:info@electronicblueprint.com.au)

## Quasar Management Services Pty Ltd

ABN 21 003 954 210 Inc in NSW

This document has been prepared by Electronic Blueprint, with engineering input by Quasar Management Services Pty Ltd.

**ELECTRONIC BLUEPRINT** is the principal point of reference for Architects, Engineers and Builders and the only package that fully integrates regulatory and standards requirements with comprehensive, editable specifications, CAD details and approved industry training.



Benex Technologies Pty. Ltd (Benex) of  
Lot 102 Canobolas Road  
ORANGE NSW 2800